

Layout & Design

GUIDELINES

for Marina Berthing Facilities

July 2005

~ Arnold Schwarzenegger, Governor, State of California ~

~ Mike Chrisman, Secretary, Resources Agency ~

~ Raynor Tsuneyoshi, Director, Department of Boating and Waterways ~

PREFACE

The engineering staff of the California Department of Boating and Waterways (DBW), Division of Boating Facilities, began writing marina berthing guidelines in the 1960s. Used over the years in the Local Assistance Loan Program, the guidelines provide technical assistance in the development of California public marinas. Originally brief and rudimentary, the guidelines have grown in scope and sophistication over the years.

The first “official” edition was dated 1968 and was incrementally revised and expanded in 1972, 1976, 1980 and 1984. The planned revision for 1988 was put on hold pending the anticipated passage of the Americans with Disabilities Act (ADA) which occurred in 1990. In 1991 the Americans with Disabilities Act Accessibility Guidelines (ADAAG) were published by the Architectural and Transportation Barriers Compliance Board (ATBCB, popularly known as the Access Board) in Washington D.C. Unfortunately, ADAAG Section 15, designated to address accessibility to recreational facilities, was “reserved” (left empty) pending further research, investigation, and public hearings by the Access Board and its staff. ADAAG 15.2 for recreational boating facilities was eventually published in 2002. In 2004, ADAAG was merged with guidelines from the 1968 Architectural Barriers Act (ABA), creating a new document known as ADA-ABA, now under review for approval by the U.S. Department of Justice. This set the final stage for the publication of the 2005 edition.

Working under the direction and supervision of Mr. Steve Watanabe, P.E., Chief of the Boating Facilities Division, the principal author of these GUIDELINES is Mr. Bill Curry, Supervising Civil Engineer (retired). Bill first began working on guidelines in 1968 for the Department of Harbors and Watercraft, which became the Department of Navigation and Ocean Development in 1969, and finally the Department of Boating and Waterways in 1979. Over the past 37 years, Bill worked with Department staff and marina professionals throughout California in pursuit of excellence in the crafting and application of guidelines. A well-deserved word of thanks is extended to those persons, agencies and organizations that participated in the process of guidelines development over the years, and to the current Boating Facilities Division staff who reviewed and commented on several drafts of this latest guideline document.

As Director of the California Department of Boating and Waterways, I extend my thanks to Bill Curry for his diligent work in producing this document. It will benefit engineers, architects, contractors, officials, marina owners and operators, and the recreational boating community statewide. Therefore, as a capstone for his distinguished career, I dedicate the **2005 Layout & Design GUIDELINES for Marina Berthing Facilities** to Bill Curry, P.E. (Retired) for the California Department of Boating and Waterways.

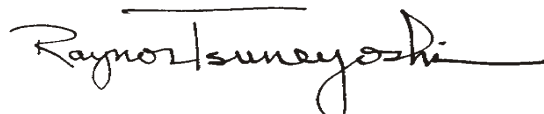

Raynor Tsuneyoshi, Director
California Department of Boating and Waterways

Special Acknowledgment

Department of
Boating and Waterways Staff

Cover by:

Sumer Boling

Graphics by:

Ken Newby

TABLE OF CONTENTS

	Page Numbers
Introduction	iii
.....	
Section A. Definitions	1
.....	
Section B. Water Areas	9
B1. General	9
B2. Channel Design Criteria	9
B3. Fairway Design Criteria	10
B4. Berth Design Criteria	10
B4.1 Berth Length and Water Depth	10
B4.2 Single Berths	11
B4.3 Double Berths	16
.....	
Section C. Berthing	21
C1. Dimensional Criteria	21
C1.1 Fingerfloats	21
C1.2 Main Walkways	22
C1.3 Marginal Walkways	23
C2. Loading	24
C2.1 Dead Load	24
C2.2 Uniform Live Load	24
C2.3 Live Point Load	25
C2.4 Lateral Loads	25
C2.5 Environmental Loads	26
C3. Freeboard	27
C4. Maximum Slopes	28
C5. Material Considerations	28
C6. Pontoons	29
C7. Decking	31
C8. Moorings	31
.....	
Section D. Guide Piles	37
D1. General	37
D2. Design Criteria	37

D3.	Material Pile Types	38
D3.1	Concrete Piles	39
D3.2	Steel Piles	40
D3.3	Wood Piles	40
D3.4	Plastic Piles	41
.....		
Section E.	Utilities	43
E1.	Utilities on Shore	43
E2.	General – Utilities in Marina Berthing Structures	43
E3.	Potable Water Service	44
E4.	Fire Suppression Systems	44
E5.	Electrical Power Service	47
.....		
Section F.	Shoreline Structures	51
F1.	Piers	51
F2.	Gangways	52
.....		
Section G.	Land Areas	59
G1.	Vehicle Parking	59
G1.1	Types of Parking Spaces	59
G1.2	Minimum Number of Parking Spaces	59
G1.3	Minimum Parking Space Dimensions	61
G1.4	General Parking Space Design Criteria	61
G2.	Restroom Facilities	62
G3.	Boat Launching Facilities	63
.....		
Appendix A: Sections B-G Commentary		65
	Section B – Water Areas	67
	Section C – Berthing	69
	Section D – Guide Piles	95
	Section E – Utilities	101
	Section F – Shoreside Structures	113
	Section G – Land Areas	121
.....		
Appendix B: ADA 15.2 / ADA-ABA 1003		125
.....		

I N T R O D U C T I O N

The primary purpose of the Layout and Design GUIDELINES for Marina Berthing Facilities is to provide technical assistance and direction in the planning, design and construction of marina berthing facilities funded under the various Local Assistance and Capital Outlay Programs administered by the Department of Boating and Waterways, Resources Agency, State of California. The GUIDELINES address typical conditions and are not intended to be all inclusive or absolute. Unique site conditions and circumstances may require special analysis, applications and design considerations not addressed herein.

The information in the GUIDELINES is useful for recreational boating facility issues in general, and will be helpful to anyone involved in the development of both new and altered boating facilities.

The GUIDELINES do not address site selection considerations for proposed new marinas, site considerations for expansion of existing ones, environmental practices, fish cleaning stations, boat engine oil recovery facilities, recycling, or permitting issues. Those matters are beyond the scope of this document.

In the presentation of layout and design criteria, the following convention is used:

- criteria printed in “standard type” are recommended general criteria; and
- criteria printed in “***bold italics***” are mandatory minimum safety or barrier-free access criteria.

It is recognized that in certain isolated instances, the application of mandatory minimum safety and accessibility criteria may not be feasible, desirable or even possible. A better alternative may exist that will not jeopardize safety or accessibility, and is judged to be equal to or better than the mandatory criteria presented herein. Deviations from the mandatory minimum criteria will be considered on a case-by-case basis jointly by the project owner, staff of the Department of Boating and Waterways, and the permitting agency(s) issuing the building permit(s). Individual project owners/operators will bear the responsibility to clearly document the rationale for any deviation(s).

It is not intended that deviations from either the recommended general criteria or the mandatory minimum safety and access criteria be used to justify wholesale departures from the advice, direction, experience and criteria presented herein. To varying degrees, the GUIDELINES represent the collective experience and wisdom of boaters, harbor masters, manufacturers, material suppliers, designers, engineers, consultants,

contractors, marina owners and operators, government officials, and various other persons and groups representing both public and private interests compiled over a period of four decades from the 1960s into the early 2000s. The intent is that the GUIDELINES will be a reliable guide for the layout and design of marina berthing facilities.

The GUIDELINES may be viewed and/or downloaded from the Department's web page as indicated below. However, it is requested that the GUIDELINES be used as a complete document, and not be edited, altered or changed in any way from its officially published form.

www.dbw.ca.gov

Should you wish to submit comments, corrections or suggestions to be considered in future editions of the GUIDELINES, or obtain hard copy of this current edition, contact the Department via the Internet, or as indicated below.

**California Department of Boating and Waterways
Boating Facilities Division
2000 Evergreen Street, Suite 100
Sacramento, California 95815-3888**

☎ (888) 326-2822

COMMENTARY FLAGS

Throughout Sections B - G, the “C” symbol in a **double-framed blue box** seen in the right margin will be seen to the right of particular sections and sub-sections. This is a “flag” indicating that commentary is provided in Appendix A on the particular subjects flagged. The commentary headings in Appendix A cite the section and sub-section references, thus providing a two-way reference system.



SECTION A

DEFINITIONS

Color Key to Definitions:

- Definitions in **bold red print** are headings for a sub-set of related definitions.
- Definitions in **bold blue print** preceded by a √ symbol are part of a sub-set.
- Definitions in **bold black print** are stand-alone definitions.

Examples:

accessible

√ **accessible boat slip**

boarding float

accessible

unless otherwise noted in context, accessible means barrier-free elements in a marina, i.e. accessible boat slip

√ **accessible boat slip**

that portion of an accessible pier, main pier, finger pier, or float where a boat is berthed

√ **accessible route**

a continuous unobstructed path connecting all accessible elements and spaces of a marina, including such features as parking access aisles, curb ramps, crosswalks at vehicular ways, walkways, ramps, lifts, gangways, boat slips, main walkways, marginal walkways, fingerfloats, boarding piers, boat launch ramps, etc.

berth

a delineated water surface mooring area, delineated by either floating or fixed dock structures, for the purposes of embarking, disembarking, and the wet storage of a recreational boat (aka *boat slip* or *boat dock*)

√ **covered berth**

a berth that is provided with a roof system to protect a berthed boat from the sun and weather

√ **single berth**

a berth designed to accommodate one (1) berthed boat, with a fingerfloat on each side of the berthed boat

√ **double berth**

a berth designed to accommodate two (2) berthed boats, with a fingerfloat on only one side of each berthed boat

boarding float a platform-type structure, either floating or fixed, stationary or adjustable; located on, along side of, or near a boat launch ramp; designed for short-term moorage of boats, and to facilitate pedestrian access to and from boats in the water; synonymous with **boarding pier**

boarding pier a portion of a pier where a boat is temporarily secured for the purpose of embarking or disembarking

Note: This is the official definition used in federal accessibility guidelines; synonymous with **boarding float**

boat launch ramp a sloped paved surface designed and constructed for launching and retrieving trailered boats and other water craft to and from a body of water

boat slip see **berth**

bull rail a low-level continuous rail along the edge of a dock, berth or pier in or over the water, intermittently blocked up to provide clear passage of boat mooring lines between the bottom of the rail and the deck surface, the purpose of which is securement of a boat; sometimes also used as a safety curbing to prevent people, carts and equipment from going over the edge of a dock, berth or pier

bulkhead a vertical (or near vertical) structural wall constructed along a shoreline to retain soil as an extension of the upland, and provide a near-shore required water depth

channel a natural or artificially dredged route on a river, bay, sea or ocean, delineated for the safe passage of boats

√ **entrance channel** a watercourse, external to a marina, through which boats travel between a marina and a water body where the primary boating activities occur

√ **interior channel** a watercourse, within a marina, through which boats travel between an entrance channel and a fairway(s)

cleat an object used (1) to secure a boat line, or (2) to provide improved traction on a gangway deck

√ **dock cleat** a raised horn-like piece of hardware fastened along the edge of a boat dock for the purpose of securing a boat

√ gangway cleat	a narrow flat bar, or series of bars, attached to the deck of a gangway to provide improved traction for pedestrians, particularly at steeper gangway slopes
cross slope	see slope
design high water	a selected high water level elevation (determined on the basis of local long-term hydrographic and/or tide data, and site-specific factors) used to design safe and durable marinas in waterways subject to infrequent extreme high water levels (extreme high tides, floods, etc.)
design low water	a selected low water level elevation (determined on the basis of local long-term hydrographic and/or tide data, and site-specific factors) used to design safe and durable marinas in waterways subject to infrequent extreme low water levels (extreme low tides, droughts, etc.)
dock	a platform, either floating or fixed, provided in a marina for the wet storage of a boat and pedestrian access to and from the boat
dump station	a facility located in a marina on docks, or on shore, specifically designed to receive sewage from portable toilets carried on vessels.
edge protection	generally refers to a raised curb or bull rail provided along the edge of an accessible dock, berth or pier to prevent a person with a disability from accidentally going over the edge and into the water
fairway	a watercourse, within a marina, by which boats travel between interior channels and marina berths
fingerfloat	see walkway
freeboard	the vertical distance from the water surface to the top of the deck of floats, docks, piers, etc., measured under various loading conditions, i.e. dead load only, live load plus dead load, etc.
fuel dock	a dedicated structure, or a delineated area on a larger pier, dock, bulkhead, or similar structure, that is specifically used for the dispensing of boat fuel (<i>aka marine service station, fuel dispensing facility, or fueling station</i>)

fuel storage tank	a storage structure (i.e. tank) that contains boat fuel in storage for dispensing
gangway	a variable slope structure that provides pedestrian access between a point on land and a floating dock that moves up and down through a range of rising and falling water levels
√ gangways, series of	two or more gangways connected by a landing(s) that collectively provide a single route of access to a floating dock as per the definition of a gangway; the length of a series of gangways does not include transition plates
√ dedicated gangway	a gangway that provides access to a single main walkway
guide pile	see pile
guardrail	see railing
handrail	see railing
harbor	a natural, or constructed, place of shelter, protection, refuge and safety for boaters as well as their necessary boats, docks, piers, goods and/or services
holding tank	any retention system on-board a boat designed and operated to receive and hold sewage, and be periodically emptied at approved pumpout sites
main walkway	see walkway
marina	a recreational boating facility on a coastal or inland waterfront that provides facilities and services for the wet and/or dry storage of boats, as well as embarking and disembarking of boat operators and passengers
marine power center	an enclosed assembly that houses electrical outlets, circuit breakers, fused switches, fuses, and/or watt-hour meters
marginal walkway	see walkway
mean higher high water (MHHW)	a tidal datum determined on the basis of the average of the higher high water heights of each tidal day observed over a protracted period of time known as the National Tidal Datum Epoch

mean lower low water (MLLW)	a tidal datum determined on the basis of the average of the lower low water heights of each tidal day observed over a period of time known as the National Tidal Datum Epoch
mooring pile	see pile
parking space	delineated space in marina parking area for the parking of vehicles of various types
√ single-vehicle parking space	a delineated parking space for a single vehicle, including passenger cars, trucks, vans, and motorcycles
√ recreational vehicle parking space	a delineated single vehicle parking space that is wider and longer than conventional single vehicle spaces in order to accommodate a single large vehicle known as a recreation vehicle (RV)
parking space, accessible	
√ accessible single-vehicle space	a marina parking space for a single vehicle that is designated by a sign and a pavement marking, and is reserved for use by a person who displays an approved placard or license plate sticker on their parked vehicle
√ accessible van vehicle space	the same as a single-vehicle space except it is marked as “van accessible” and is wider than a single-vehicle space; van vehicle spaces are designated and reserved for barrier-free use, but are not designated for the exclusive parking of vans
pier	a structure extending over the water and supported on a fixed foundation (fixed pier), or on flotation (floating pier), that provides access to the water
pile	a long slender structural member, typically of wood, concrete, steel or plastic construction, driven into the bottom of a marina basin to secure and guide docks
√ guide pile	a pile that holds marina floating docks on location, and allows the docks to rise and fall with changing water levels

√ mooring pile	a pile at the entrance to and in the center of a double berth, to which the berthed boats may be secured
pumpout station	a facility that pumps out and receives sewage from a Type III marine sanitation device (holding tank) on-board a boat
√ Type III MSD	a holding tank installed on-board a boat to receive and retain untreated sewage for shore-based disposal, transfer to an authorized mobile unit, or discharge beyond the 3 mile offshore limit except within federally designated No-Discharge Areas
railing	
√ handrail	a railing on a stairway, ramp, walkway or gangway, for pedestrians to grasp with their hand(s) for support
√ guard rail	a railing system, including a top rail, located along the edge of an elevated walking surface for the purpose of minimizing the possibility of an accidental fall from the walking surface to a lower level; same as safety rail
√ safety rail	same as guard rail
ramp	a pedestrian walkway on an accessible route, with a constant running slope greater than 1:20 (5%) but not greater than 1:12 (8.33%), a maximum rise of 30 inches, and a maximum cross slope of 1:50 (2%)
rode	the line or chain that connects a buoy to an anchor
safety rail	see railing
service float	a floating structure equipped to supply oil, fuel, water, sewage pumpout, and other related services to boats
shall	“ shall ” indicates mandatory minimum safety requirements, and barrier-free access requirements (see explanatory comments regarding this format convention in the Introduction, page iii)
should	“should” indicates a recommendation, i.e. that which is advisory but not mandatory
slip	see berth

slope	the inclination of a dock, gangway, or walkway component measured as the tangent (vertical / horizontal) of the angle between the component surface and a level reference line
√ cross slope	the slope of the deck of a floating walkway or fingerfloat, measured perpendicular to the primary direction of travel
√ longitudinal slope	the slope of the deck of a floating walkway or fingerfloat, measured parallel to the primary direction of travel
toe plate	a sloping plate, hinged to the lower end of a gangway, that provides a smooth transition between the variable slope gangway and the deck of a floating dock
transition plate	a sloping plate, hinged to the upper and/or lower end of an accessible gangway, that provides a smooth transition between the gangway and a floating dock or landing

Note: The term **transition plate** is exclusively used with reference to barrier-free access to marina gangways, and does not refer to various types of plates that span between adjacent sections of floating docks, boarding floats, etc.

walkway

√ fingerfloat	a finger-like floating structure typically attached perpendicular to a main walkway, that together define the length and width of a berth, provide direct pedestrian access to and from a boat in the berth, provide for the secure mooring of a boat in the berth, and may support the provision of various utility services
√ main walkway	a floating structure to which fingerfloats are attached to define individual berths and to provide pedestrian access between the berths and a marginal walkway or shore
√ marginal walkway	a floating structure that provides pedestrian access between two or more main walkways and shore, and may serve as a platform for lighting, fuel stations, sewage pumpout facilities, lift stations, and utility lines
toilet fixture	toilet (water closet), urinal, and/or lavatory in a marina
waler	a structural member(s) fastened along the edges of a dock system to hold it together, provide stability, and protect the flotation pontoons and utilities

SECTION B

WATER AREAS

B1. General

B1.1 The design depths and widths of various water areas within a recreational boat marina must take into consideration the sizes and types of boats expected to use the marina, wave action, currents, water level fluctuations, levels of seasonal boat traffic, silt deposition rates and anticipated frequencies of dredging in order to maintain the minimum design depths over projected dredging intervals, usually measured in years. Recommended design depths are exclusive of site-specific requirements for additional depths necessary to store estimated silt accretion that occurs between scheduled dredging intervals.

B2. Channel Design Criteria

B2.1 Design depths for a specific marina must be based on a design low water elevation established on the basis of a low water datum for the area or reliable long-term extreme low water data obtained from federal, state and local water authorities. Such information should include low tide levels, lowest recorded water depths, etc., in salt water or fresh water locations as required.

B2.2 Required minimum depths below design low water must be objectively determined on the basis of the type (power or sail), length and draft of the boats expected to be berthed in a marina, or specific sections within a larger marina.

The table below provides minimum water depths below design low water, but does not address additional depths that may be necessary for silt deposition storage between periodic dredging operations.

Table B - 1 Minimum Channel Widths and Depths

Channels: →	Entrance Channel	Interior Channel
Minimum Bottom Width:	75 ft	75 ft
Minimum Depth Below Design Low Water:	3 ft below deepest draft boat or 5 ft, whichever is greater	2 ft below deepest draft boat or 4 ft, whichever is greater

B3. Fairway Design Criteria

Table B - 2 Minimum Fairway Widths and Depths

Fairways →	Without Side-Ties	With Side-Ties
Minimum Width	1.75 L _b L _b = length of longest berth <i>perpendicular</i> to the fairway.	1.50 L _{bb} L _{bb} = length of longest boat side-tied <i>parallel</i> to fairway.
	If boats longer than the berths will be allowed to overhang into the fairway, L _b should be considered to be the length of the boats.	The minimum width of the fairway does not include the width of the side-tie berth. See Tables B - 5 and B - 6 for powerboat and sail boat berth widths.
Minimum Depth	Same as for Interior Channels See Table B - 1	

B4. Berth Design Criteria

B4.1 Berth Length and Water Depth

Table B - 3 Minimum Berth Depth

Berth Length (feet)	Minimum Berth Water Depth (feet)	
	Powerboats	Sailboats
Up to 45 ft	6 ft	6 ft
Up to 55 ft	8 ft	8 ft
Up to 65 ft	8 ft	10 ft
Over 65 ft	Site Specific Determination	

B4.1.1 The values shown in Table B - 3 reflect only the minimum depth requirements for berths of various length ranges. These minimum water depths must be applied with reference to site specific historic low water level data such as tide tables for coastal marinas, and hydrographic records for river and lake marinas.



B4.1.2 For the purpose of these guidelines, the berth length is considered to be the actual length of the dock or pier that defines the berth, i.e. the length of fingerfloats.

B4.1.3 In cases where the berth length cannot be determined, as in the case of a long dock without fingerfloats, each 40 feet will be considered as a berth, particularly for the purpose of determining the total number of berths in a marina to compute the required minimum number of accessible berths. See Section B5.1.1.

B4.2 Single Berths

B4.2.1 Minimum Single Berth Widths

See Table B-4 below, where:

- L_{sb} = length of single berth
- W_{sbp} = width of single berth for powerboat
- W_{sbs} = width of single berth for sailboat
- \ln = \log^n

Table B - 4 Minimum Single Berth Widths

Application ↓	Minimum Widths of Single Berths (feet)	
	Powerboats	Sailboats
Design Work	$W_{sbp} = 8 \ln L_{sb} - 14 \text{ ft}$	$W_{sbs} = 6.5 \ln L_{sb} - 10.5 \text{ ft}$
Useful for Preliminary Layout and Planning Work	$W_{sbp} = (L_{sb} / 4) + 6 \text{ ft} - R_{pb}$ $R_{pb} =$ Reduction Factor for powerboats = 0.20 ft per ft of berth length under 30 ft and 0.125 ft per ft over 40 ft	$W_{sbs} = (L_{sb} / 5) + 5.5 \text{ ft} - R_{sb}$ $R_{sb} =$ Reduction Factor for sailboats = 0.125 ft per ft of berth length under 30 ft and 0.075 ft per ft over 40 ft.
	Note: The widths of recreational boat berths are generally based on average boat beams + 2 feet.	

B4.2.2 The equations for design work will probably be used most of the time for both planning and design work. However, the equations for preliminary layout and planning work should not be disregarded. They can be memorized and used in the field without the aid of a table or a calculator, and are a valuable aid in computing potential berth widths “in your head” when on site and in meetings. As shown for both powerboats and sailboats in Table B - 5 and Table B - 6 respectively, the two types of equations give similar results.

Table B-5 Single Berth Widths for Powerboats

Single Berth Widths for Powerboats 0.20 ft reduction per ft below 30 ft 0.125 ft reduction per ft above 40 ft					
Berth Length (ft)	Width Design Formula 8 In L_b - 14 (ft)	Preliminary Layout & Planning Width Reduction			Recommended Berth Width (ft)
		$(L_b / 4) + 6.0 - R_{pb} = \text{Reduced Width (ft)}$			
16	8.2	10.0	-2.8	7.2	7.0
18	9.1	10.5	-2.4	8.1	8.0
20	10.0	11.0	-2.0	9.0	9.0
22	10.7	11.5	-1.6	9.9	10.0
24	11.4	12.0	-1.2	10.8	11.0
26	12.1	12.5	-0.8	11.7	12.0
28	12.7	13.0	-0.4	12.6	12.5
30	13.2	13.5			13.5
32	13.7	14.0			14.0
34	14.2	14.5			14.5
36	14.7	15.0			15.0
38	15.1	15.5			15.5
40	15.5	16.0			16.0
42	15.9	16.5	-0.25	16.25	16.0
44	16.3	17.0	-0.50	16.50	16.5
46	16.6	17.5	-0.75	16.75	16.5
48	17.0	18.0	-1.00	17.00	17.0
50	17.3	18.5	-1.25	17.25	17.0
52	17.6	19.0	-1.50	17.50	17.5
54	17.9	19.5	-1.75	17.75	17.5
56	18.2	20.0	-2.00	18.00	18.0
58	18.5	20.5	-2.25	18.25	18.0
60	18.8	21.0	-2.50	18.50	18.5
62	19.0	21.5	-2.75	18.75	18.5
64	19.3	22.0	-3.00	19.00	19.0
66	19.5	22.5	-3.25	19.25	19.0
68	19.8	23.0	-3.50	19.50	19.5
70	20.0	23.5	-3.75	19.75	19.5
72	20.2	24.0	-4.00	20.00	20.0
74	20.4	24.5	-4.25	20.25	20.0
76	20.6	25.0	-4.50	20.50	20.5
78	20.9	25.5	-4.75	20.75	20.5
80	21.1	26.0	-5.00	21.00	21.0

Table B-6 Single Berth Widths for Sailboats

Single Berth Widths for Sailboats 0.125 ft reduction per ft below 30 ft 0.075 ft reduction per foot above 40 ft					
Berth Lengths (ft)	Width Design Formula 6.5 ln L _b - 10.5 (ft)	Preliminary Layout & Planning Width Reduction			Recommended Berth Widths (ft)
		$(L_b / 5) + 5.5 - R_{sb} = \text{Reduced Width (ft)}$			
16	7.5	8.7	-1.75	6.95	7.0
18	8.3	9.1	-1.50	7.60	8.0
20	9.0	9.5	-1.25	8.25	8.5
22	9.6	9.9	-1.00	8.90	9.5
24	10.2	10.3	-0.75	9.55	10.0
26	10.7	10.7	-0.50	10.20	10.5
28	11.2	11.1	-0.25	10.85	11.0
30	11.6	11.5			11.5
32	12.0	11.9			12.0
34	12.4	12.3			12.5
36	12.8	12.7			13.0
38	13.1	13.1			13.0
40	13.5	13.5			13.5
42	13.8	13.9	-0.15	13.75	14.0
44	14.1	14.3	-0.30	14.00	14.0
46	14.4	14.7	-0.45	14.25	14.5
48	14.7	15.1	-0.60	14.50	14.5
50	14.9	15.5	-0.75	14.75	15.0
52	15.2	15.9	-0.90	15.00	15.0
54	15.4	16.3	-1.05	15.25	15.5
56	15.7	16.7	-1.20	15.50	15.5
58	15.9	17.1	-1.35	15.75	16.0
60	16.1	17.5	-1.50	16.00	16.0
62	16.3	17.9	-1.65	16.25	16.5
64	16.5	18.3	-1.80	16.50	16.5
66	16.7	18.7	-1.95	16.75	17.0
68	16.9	19.1	-2.10	17.00	17.0
70	17.1	19.5	-2.25	17.25	17.5
72	17.3	19.9	-2.40	17.50	17.5
74	17.5	20.3	-2.55	17.75	18.0
76	17.6	20.7	-2.70	18.00	18.0
78	17.8	21.1	-2.85	18.25	18.5
80	18.0	21.5	-3.00	18.50	18.5

**Table B-7
SINGLE BERTH LAYOUT PLANNING DATA**

"F" Width of Finger (ft)	"L _b " Length of Berth (ft)	Powerboats			Sailboats		
		Numbered Equations: See Table B-8					
		1	2	3	4	5	6
		Total Berth Area (ft ²)	Actual Deck Area (ft ²)	Berths per Acre	Total Berth Area (ft ²)	Actual Deck Area (ft ²)	Berths per Acre
2.5	16	352.5	72.0	123.6	330.7	70.1	131.7
	18	427.1	79.9	102.0	396.4	77.4	109.9
	20	504.9	87.4	86.3	464.6	84.4	93.8
3.0	22	607.5	107.2	71.7	557.2	103.8	78.2
	24	692.4	115.3	62.9	631.6	111.5	69.0
	26	779.6	123.2	55.9	707.8	119.0	61.5
	28	869.0	131.0	50.1	785.8	126.5	55.4
	30	960.4	138.6	45.4	865.5	133.8	50.3
	32	1053.7	146.2	41.3	946.7	141.1	46.0
	34	1148.8	153.6	37.9	1029.4	148.3	42.3
4.0	36	1316.1	200.0	33.1	1183.9	194.4	36.8
	38	1418.2	209.3	30.7	1273.0	203.4	34.2
	40	1521.9	218.5	28.6	1363.3	212.4	32.0
	42	1626.9	227.7	26.8	1454.7	221.4	29.9
	44	1733.4	236.8	25.1	1547.3	230.3	28.2
	46	1841.1	245.9	23.7	1641.0	239.2	26.5
	48	1950.2	254.9	22.3	1735.6	248.0	25.1
	50	2060.4	263.9	21.1	1831.3	256.8	23.8
	52	2171.8	272.8	20.1	1927.9	265.5	22.6
	54	2284.3	281.7	19.1	2025.4	274.3	21.5
	56	2397.9	290.6	18.2	2123.8	283.0	20.5
	58	2512.5	299.5	17.3	2223.0	291.7	19.6
60	2628.2	308.3	16.6	2323.1	300.3	18.8	
5.0	62	2864.0	382.1	15.2	2543.2	374.0	17.1
	64	2985.3	392.8	14.6	2648.5	384.6	16.4
	66	3107.6	403.6	14.0	2754.6	395.2	15.8
	68	3230.7	414.3	13.5	2861.4	405.8	15.2
	70	3354.6	425.0	13.0	2969.0	416.3	14.7
	72	3479.4	435.6	12.5	3077.2	426.9	14.2
	74	3605.1	446.3	12.1	3186.0	437.4	13.7
	76	3731.5	456.9	11.7	3295.5	447.9	13.2
	78	3858.7	467.6	11.3	3405.7	458.5	12.8
	80	3986.6	478.2	10.9	3516.4	468.9	12.4

FIGURE B-1 SINGLE BERTH LAYOUT SCHEME

(BASED ON 6FT WIDE MAIN WALKWAY)

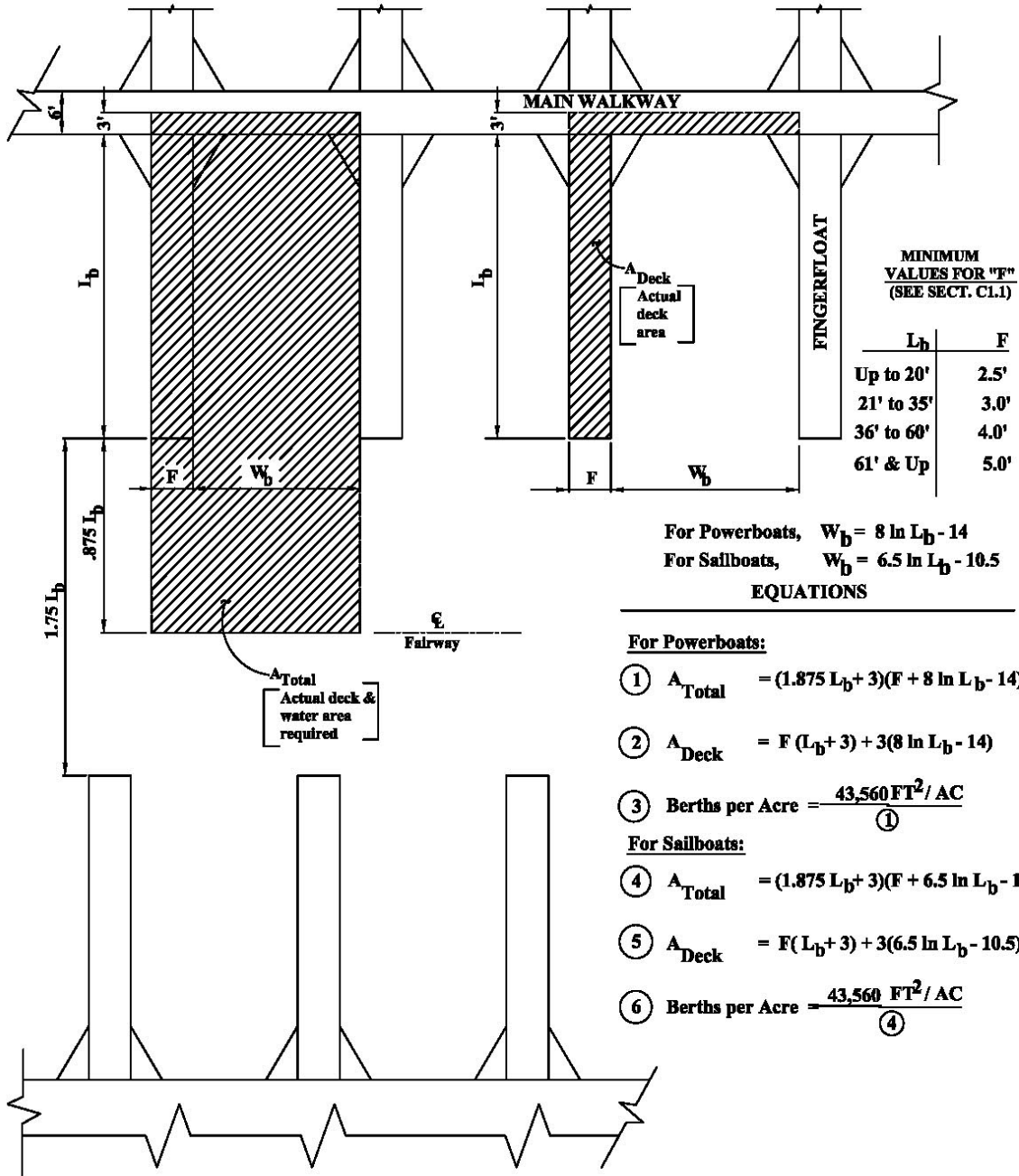

B4.3 Double Berths

B4.3.1 Minimum Width for Double Berths of Same Length

Unless otherwise necessary, a double berth will typically be twice the width of a single berth of the same length.

$$\begin{aligned} W_{db} &= \text{width of double berth} \\ &= W_{sb} \times 2 \end{aligned}$$

B4.3.2 Minimum Width for Double Berths of Different Lengths

Where a double berth consists of two single berths of different lengths, the double berth width (W_{db}) will be equal to the sum of the two single berth widths (W_b) based on their lengths:

$$W_{db} = W_{sb1} + W_{sb2}$$

B4.3.3 Where it is desired to install a fingerfloat to divide an existing double berth into two single berths, additional berth width must be provided for the fingerfloat to avoid reduction of the design widths of the two single berths.

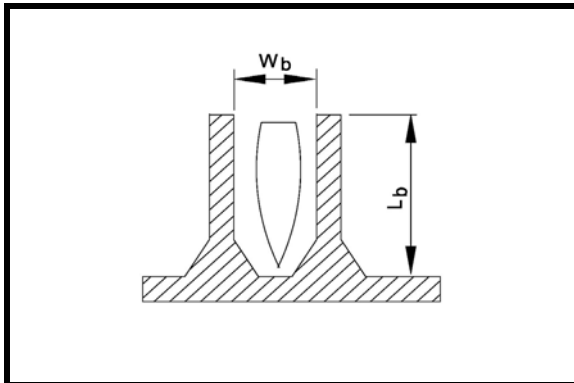

Single Berth – Equal Length Fingerfloats

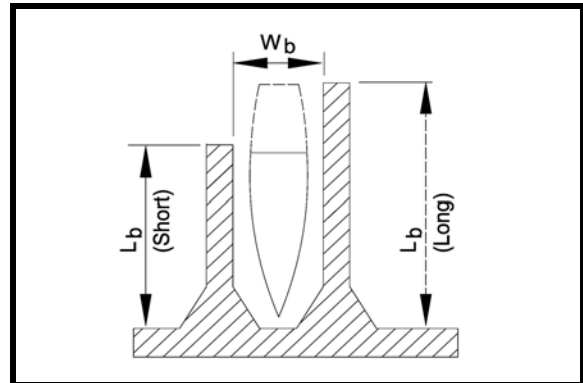

Single Berth – Unequal Length Fingerfloats

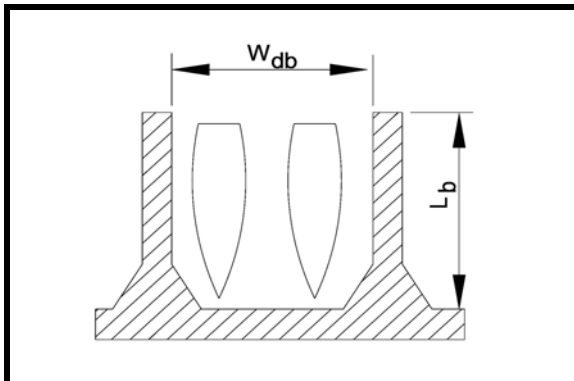

Double Berth – Equal Length Fingerfloats

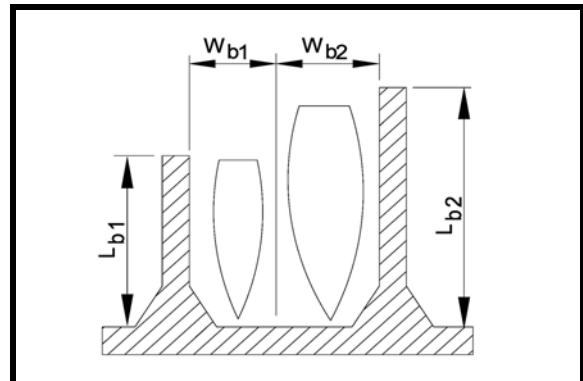

Double Berth – Unequal Length Fingerfloats

**Table B-8
DOUBLE BERTH LAYOUT PLANNING DATA**

“F” Width of Finger (ft)	“L _b ” Length of Berth (ft)	Powerboats			Sailboats		
		Numbered Equations: See Table B-10					
		7	8	9	10	11	12
		Total Berth Area (ft ²)	Actual Deck Area (ft ²)	Berths per Acre	Total Berth Area (ft ²)	Actual Deck Area (ft ²)	Berths per Acre
2.5	16	311.2	48.3	140.0	289.5	46.3	150.5
	18	381.2	53.6	114.3	350.5	51.1	124.3
	20	454.2	58.6	95.9	414.0	55.7	105.2
3.0	22	541.1	69.7	80.5	490.8	66.3	88.8
	24	620.4	74.8	70.2	559.6	71.0	77.8
	26	702.0	79.7	62.1	630.2	75.5	69.1
	28	785.7	84.5	55.4	702.6	80.0	62.0
	30	871.5	89.1	50.0	776.6	84.3	56.1
	32	959.2	93.7	45.4	852.2	88.6	51.1
	34	1048.7	98.1	41.5	929.2	92.8	46.9
4.0	36	1175.1	122.0	37.1	1042.9	116.4	41.8
	38	1269.7	127.3	34.3	1124.5	121.4	38.7
	40	1365.9	132.5	31.9	1207.3	126.4	36.1
	42	1463.4	137.7	29.8	1291.2	131.4	33.7
	44	1562.4	142.8	27.9	1376.3	136.3	31.6
	46	1662.6	147.9	26.2	1462.5	141.2	29.8
	48	1764.2	152.9	24.7	1549.6	146.0	28.1
	50	1866.9	157.9	23.3	1637.8	150.8	26.6
	52	1970.8	162.8	22.1	1726.9	155.5	25.2
	54	2075.8	167.7	21.0	1816.9	160.3	24.0
	56	2181.9	172.6	20.0	1907.8	165.0	22.8
	58	2289.0	177.5	19.0	1999.5	169.7	21.8
60	2397.2	182.3	18.2	2092.1	174.3	20.8	
5.0	62	2565.9	219.6	17.0	2245.0	211.5	19.4
	64	2677.8	225.3	16.3	2341.0	217.1	18.6
	66	2790.7	231.1	15.6	2437.8	222.7	17.9
	68	2904.4	236.8	15.0	2535.2	228.3	17.2
	70	3019.0	242.5	14.4	2633.3	233.8	16.5
	72	3134.4	248.1	13.9	2732.2	239.4	15.9
	74	3250.7	253.8	13.4	2831.7	244.9	15.4
	76	3367.7	259.4	12.9	2931.8	250.4	14.9
	78	3485.5	265.1	12.5	3032.6	256.0	14.4
	80	3604.1	270.7	12.1	3133.9	261.4	13.9

FIGURE B-2 DOUBLE BERTH LAYOUT SCHEME (BASED ON 6FT WIDE MAIN WALKWAY)

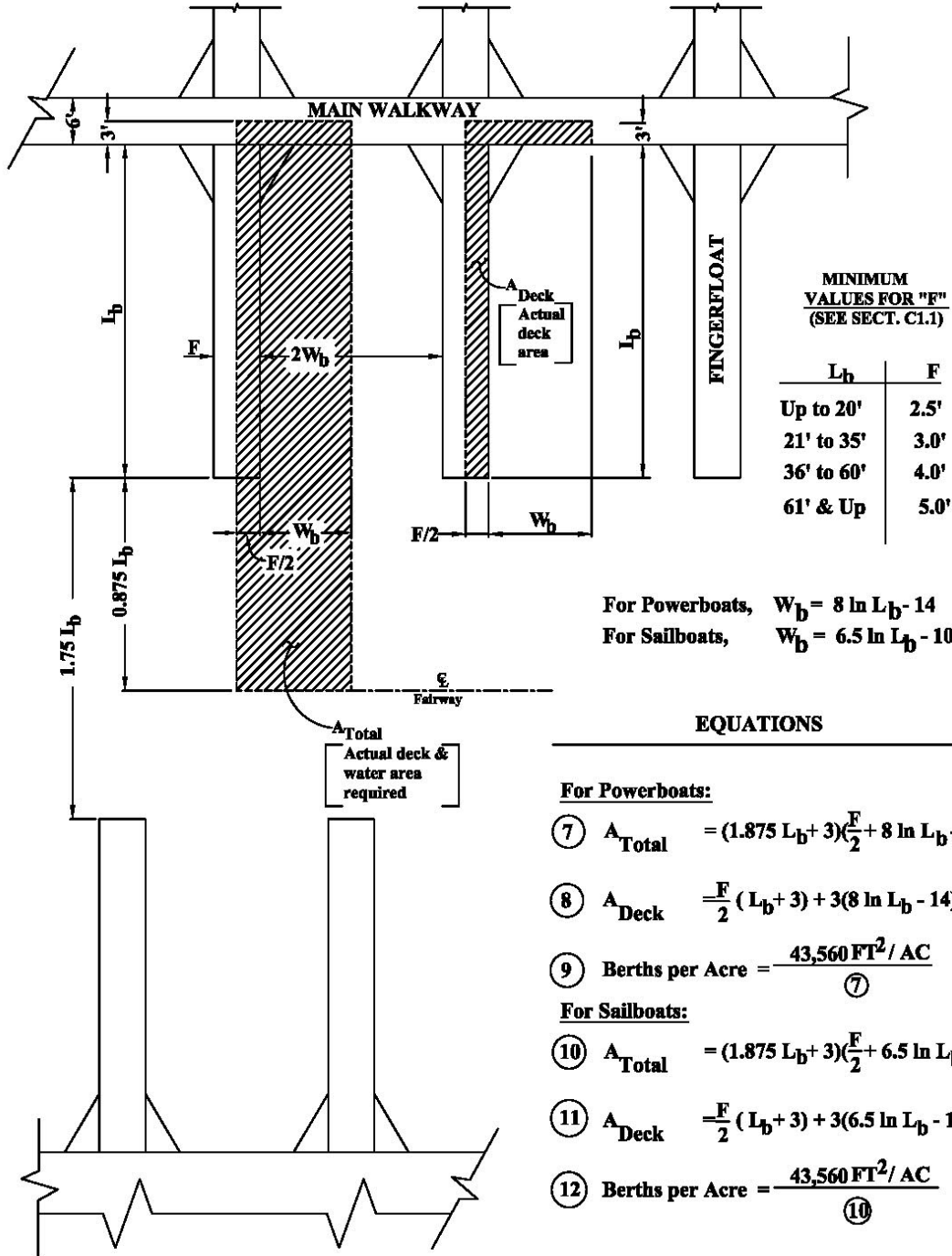

B5. Minimum Required Number of Accessible Berths

B5.1 *The minimum required number of accessible berths shall be provided as per Table B5.1.*

B5.1.1 *Where the number of boat slips is not identified, such as along the edge of a long side-tie dock for example, each 40 feet of linear dock edge, or fraction thereof, shall be counted as one boat slip.*

Example: A side-tie dock 375 ft long would be considered to be 10 berths.

B5.1.2 The total number of berths in a marina facility must include all single berths, double berths, side-tie berths, end-tie berths, open berths and covered berths, as well as berths that are components of courtesy landings, visitor docks, fuel docks, sewage pumpout docks, harbor master office docks, haul out and repair docks, etc.

**Table B-9
Minimum Required Number
of Accessible Berths**
(ADAAG Table 15.2.3)

Total Number of Boat Slips	Minimum Number
1 to 25	1
26 to 50	2
51 to 100	3
101 to 150	4
151 to 300	5
301 to 400	6
401 to 500	7
501 to 600	8
601 to 700	9
701 to 800	10
810 to 900	11
901 to 1000	12
1001 and over	12, plus 1 for each 100 or fraction thereof over 1000

SECTION C BERTHING

C1. Dimensional Criteria

C1.1 Fingerfloats

Table C-1
Minimum Fingerfloat Width

Fingerfloats	
Minimum Width	Length Range
5.0 ft	all accessible fingerfloats
2.5 ft	below 20 ft
3.0 ft	20 ft & over
4.0 ft	36 ft & over
5.0 ft	60 ft & over
6.0 ft	80 ft & over
8.0 ft	120 ft & over



View of Fingerfloat Clear Width Including Walers

C1.1.2 Minimum fingerfloat width dimensions are considered to be “clear” widths. Cleats or rings along the top edge of a fingerfloat, and hoses and power cords connected to utility pedestals, should not be considered to be reductions of the clear width of fingerfloats. However, ***hoses and power cords shall not be allowed to lay across an accessible fingerfloat.***



Fingerfloat Cleat Attached to Inside Waler

C1.1.3 The clear width will often include the thickness of walers along the sides of fingerfloats. In some dock structures the widths of single or double walers can add 3 to 7 inches of width to each side of a fingerfloat, amounting to an additional overall width of 6 to 14

inches. The fingerfloat waler width must be considered in designing the actual clear width of a berth. If ignored or overlooked, it can result in reduction of the clear width of the berth. This is even more critical on single berths since walers are on both sides of the berth.



Double Waler Fingerfloat

C1.1.4 These guidelines do not specifically address berth lengths over 80 feet. However, Table C-1 shows recommended widths for berths up to 120 ft to address the growing demand for larger berths in some coastal marinas. Special attention must be paid to boat length, beam and draft.

C1.2 Main Walkways

C1.2.1 Minimum Widths

**Table C-2
Minimum Main Walkway Width**

Main Walkways	
Minimum Width	Length Range
6.0 ft	below 300 ft
8.0 ft	300 ft & over
See C1.2.2.1 regarding uniform widths of long main walkways.	

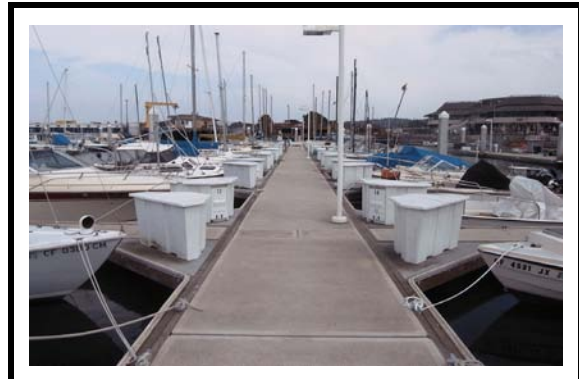

Main Walkway - Fingerfloats Both Sides

C1.2.1.1 Width dimensions are generally considered to be “clear” widths. Piles, light standards, telephone and fire call boxes, etc. along the edge should not be considered violations of the clear width criteria.

C1.2.1.1.1 Intermittent width reductions shall be kept to a minimum on accessible route walkways, and encroachment into the clear width by any part of berthed boats shall not be allowed.

C1.2.1.2 When designing a new or altered marina, the minimum width criteria must be applied in conjunction with design criteria for fairway widths, berth lengths and the inventory of berth sizes being planned. Otherwise, discontinuities of both fairway and dock alignments will result.



C1.2.2 Main Walkways – Maximum Length

700 feet is a practical maximum length of a main walkway.



C1.2.2.1 The clear width of a main walkway should be of uniform width throughout its length. Otherwise, problems will occur with regard to utilities and the clean orderly alignment of fingerfloats and fairways.



Long Uniform-Width Main Walkway

C1.3 Marginal Walkways

C1.3.1 Minimum Widths

**Table C-3
Minimum Marginal Walkway Widths**



Marginal Walkways		
Minimum Width	Length Range	Qualifying Criteria
6.0 ft	up to 300 ft	when connected to main walkways that do have dedicated gangways
8.0 ft	over 300 ft	when connected to main walkways that do not have dedicated gangways
10.0 ft	over 600 ft	
12.0 ft	over 800 ft	

C1.3.1.1 As length increases, width must increase in consideration of:

- increased pedestrian traffic and maintenance activities;
- movement of supplies, equipment and gear;
- larger utility lines and pull boxes;
- lighting needs; and
- emergency access for rescue and law enforcement personnel.

C1.3.2 Marginal Walkways – Maximum Lengths



C1.3.2.1 1,000 feet is a practical maximum length in consideration of:

- walking distances between berths, parking areas and restrooms;
- hauling supplies, equipment and gear to and from a boat;
- utility line size increases because of long walkway lengths;
- potential voltage losses in electrical circuits;
- possible need for additional transformers; and
- more utility lines, fittings and equipment dead loads on docks.

C2. Loading

C2.1 Dead Load (DL)

C2.1.1 The total dead load of a floating dock system is the combination of concentrated and uniformly distributed weights of all framing, decking, nuts, bolts, washers, connectors, flotation pontoons, and all permanently attached equipment such as pipes, lines, pumps, utilities, fuel facilities, sewage systems, fire suppression systems, gangways, lighting, storage boxes, utility cabinets, etc. The determination of total dead loads should also include the estimated weight of items that will be stored in storage boxes, and the weight of the fluids in various utility lines and related equipment.



Dead Load on a Dock:
Electrical Transformer Cabinet

C2.1.2 Care must be taken in locating various dead load elements to insure that flat and reasonably level deck surfaces are maintained throughout the service life of the dock system. Overloaded storage boxes or large diameter water lines on only one side of a dock can alter the freeboard and deck slopes.

C2.1.3 *Cross slopes under dead load only shall not exceed 2% (1:50) on docks that are part of an accessible route.*



C2.1.4 The dead weight of lumber and wood timbers utilized in a floating dock system should be assumed to weigh not less than 35 lbs. per cubic foot at specified moisture contents following pressure treatment.

C2.2 Uniform Live Load (ULL) 25 pounds per sq ft minimum

C2.2.1 25#/ft² is a guideline that is time tested and can be relied upon to be reasonable in its application. Floating docks in marinas should meet all freeboard and deck slope guidelines under the minimum ULL.



C2.2.1.1 There may be circumstances in which the application of a 25#/ft² ULL is actually in conflict with practical dock design and construction considerations under unique local conditions.



C2.2.2 Snow and ice loads will be part of the ULL in certain locations. Sustained snow loads and ice buildup can exceed 25#/ft², depending on water content. These loads can linger for weeks or months unless the docks are cleared or warmer weather returns. It is prudent to check with local authorities for required or recommended design snow and ice loadings.



C2.2.3 ULL of 40#/ft² may be necessary for design purposes in marina locations where floating dock systems are subjected to regular and repeated high volumes of pedestrian traffic and the movement of goods, materials, supplies, cargo, etc. Special events such as boat shows where queuing for shuttles, ferries, etc., may call for the higher ULL on impacted marinas.



High Volume Pedestrian Traffic

C

C2.3 Live Point Load (LPL)
400 pounds minimum

C2.3.1 Floating docks in marinas are to meet all freeboard and deck slope requirements under a minimum LPL of 400#, applied at any point on the deck not closer than 12" from any edge. This realistically addresses the center of gravity of the general array of heavy objects that are likely to be rolled over the surface of, or temporarily placed upon a marina dock. A typical LPL might be an outboard engine, stacked boxes of supplies for a cruise, or an adult person in a heavy-duty battery-powered wheelchair. The 400# LPL will cover the majority of typical temporary loads that are likely to occur on a marina dock.

C2.3.2 Where the application of a heavier LPL is anticipated, especially along an accessible route, design loads require careful attention with regard to freeboard and cross slopes.

C2.3.3 *Where applied along an accessible route, the minimum 400# LPL shall be applied concurrently with the minimum 25#/ft² ULL to insure that maximum cross slopes are not exceeded.*

C2.4 Lateral Loads (WinL, CL, WavL, IL)

Lateral loads on a dock system may result from winds, currents, waves, and impacts. Such loads may be imparted to docks, boats tied up to docks, or both concurrently. Such loadings may be influenced by seasonal factors that may dictate that two or more types of lateral loads be applied concurrently.

C2.4.1 Wind loads (WinL) on the projected vertical surfaces of docks and berthed boats should be not less than 15#/ft², applied above the water surface. If established wind data at specific locations dictates, a higher unit WinL may be necessary.

C2.4.2 Current loads (CL) should be calculated on the basis of the maximum currents, flood flows, tidal flows, and/or other site-specific lateral (horizontal) moving water loadings that can be anticipated at a given marina site. The determination of current loads must include consideration of reversals of flow

C

C

with changing tides, eddies in rivers, and anomalies that can occur in complex water systems where a failed levee event can cause a temporary reversal of direction of flow in a river or slough.

C2.4.3 Wave loads (WavL) should be calculated on the basis of the maximum wave that can be expected to occur within a marina basin, caused by the highest significant wave impinging on the protective works of the marina basin; or the maximum wind wave that can set up within the marina basin, whichever is greater.

C2.4.4 Impact loads (IL) to both floating docks and berthed boats are primarily caused by vessels of varying sizes underway within a marina. Such impact events usually occur in main channels and fairways. The determination of impact loads is based on the length and weight of the impacting boat, its angle of impact, and its velocity at impact.



C2.5 Environmental Loads

C2.5.1 Waterway debris loadings on marina dock systems may occur because of unique local conditions. River based marinas are subject to flood events that bring large quantities of limbs, branches, logs, trees, root balls, propane tanks, travel trailers, abandoned boats, swept away docks, piles and other large debris that pile up against a marina and its berthed boats.

C2.5.1.1 The location and magnitude of potential waterway debris loading is virtually impossible to accurately anticipate and calculate. However, prudent marina designers should investigate the history of a waterway upon which a marina is being planned, interview personnel and owners of existing nearby marinas, and make diligent efforts to discover and quantify the loadings that may occur. Based on this data and information, estimated design loads can be developed to design and construct a marina that will likely withstand such environmental loadings. The final design in a river may very well include an upstream debris boom to deflect floating debris and encourage it to pass around a marina rather than through it.



Upstream Debris Deflection Boom

C2.5.1.2 River based marinas near low bridges are special cases, including marinas upstream or downstream from a bridge. A low bridge is one that can be impacted by anything in the river at high water. The



definition of “near” cannot be identified in terms of feet or miles, but must be determined by the character of the river itself, including bends, tangents, forks, stream flows, velocities, levee characteristics and the presence of other physical features that influence where quantities of debris would likely flow during a flood event.



River Marina Viewed From Low Bridge

C2.5.2 Wildlife loading can occur in marinas, involving ducks, geese, sea lions, harbor seals and other natural residents that live in and near the water. When such a condition occurs with wildlife, it can cause partial or total shutdown of a marina. Along the coast where certain marine animals are protected by federal law, and enforced by NOAA Fisheries, it may be very difficult or illegal to remove wildlife from docks and boats for certain periods of time. When such events occur in a marina, solutions can usually be worked out cooperatively with personnel from federal, state and local environmental authorities.



Sea Lions in Boats



Sea Lions on Docks

C3. Freeboard

- C3.1 Under DL only:
 - Minimum Freeboard 14 inches
 - Maximum Freeboard 24 inches
- C3.2 Under DL + ULL:
 - Minimum Freeboard 10 inches
- C3.3 Under DL + LPL:
 - Minimum Freeboard 10 inches



C4. Maximum Slopes

- C4.1 Under DL only, and DL + ULL:
 - Maximum Cross Slope
1/4 inch per foot, not to exceed 1 inch maximum

 - Maximum Longitudinal Slope
1/8 inch per foot, not to exceed 1 inch in 10 feet

- C4.2 Under DL + LPL:
 - Maximum Cross Slope
1/2 inch per foot (4%), not to exceed 2 inches maximum

 - Maximum Longitudinal Slope
1/4 inch per foot, not to exceed 2 inches in 10 feet

- C4.3 On Accessible Routes, Under DL only, DL + ULL, or DL + LPL:
 - Maximum Cross Slope**
Shall not exceed 1:50 (2%)

 - Maximum Longitudinal Slope
Note: The maximum allowable longitudinal slopes in C4.1 and C4.2 are well below the 1:20 (5%) slope that defines a “ramp”. Marina walkways are typically very flat in slope, and consequently provide excellent accessibility with regard to maximum longitudinal slopes.

- C4.4 ***The ULL and LPL shall be applied concurrently along accessible routes in order to insure that maximum cross slopes are not exceeded.*** The maximum allowable cross slope on a accessible route is 1:50 (2%). This requirement applies to gangways, marginal walkways, main walkways, fingerfloats, courtesy landing docks, fuel docks, sewage pumpout station docks, and any other floating structures that are part of an accessible route in a marina. All of these components link together to provide the accessible route that serves all marina primary function areas.

C5. Material Considerations

- C5.1 In selecting materials for berthing systems, keep the following in mind:

<ul style="list-style-type: none"> ■ corrosion resistance ■ impact resistance ■ strength of materials ■ minimum thickness ■ ultraviolet resistance ■ cost ■ flexibility ■ ease of maintenance ■ vandalism 	<ul style="list-style-type: none"> ■ availability ■ pleasing appearance ■ past performance ■ decking texture / traction ■ local code requirements ■ weight ■ color ■ dissimilar metal galvanic corrosion ■ thermal expansion and contraction
--	---

C6. Pontoons

C6.1 Pontoons in floating marina berthing systems are the components that provide the flotation capacity to support all loads that may occur during the service life of a marina. The heavier the combined loadings, the greater the required pontoon capacity to maintain required freeboard, cross slopes, etc.



C6.2 Marina pontoons are typically manufactured from concrete, polyethylene plastic, fiberglass, aluminum and steel. Pontoon material selection must include consideration of environmental influences, the nature of the berthing frame system, pontoon flotation characteristics, availability and cost. Environmental influences include salt water, fresh water, currents, waves, tides, flooding, wind, storms, extreme temperatures, ultraviolet exposure, impacts, and potential seismic activity.

C6.3 Pontoons must be selected and designed to be compatible with the dock frame regarding fastening details, ease of repair and/or replacement if necessary, flexibility/stiffness, and performance.



C6.4 Most pontoons used in marinas consist of an outer pontoon shell of concrete, plastic or metal. **Hollow marina pontoons shall be filled with new expanded foam** to insure continued flotation if the shells leak, as they most probably will. Pontoon foam can be polystyrene or polyurethane, but should be either (1) expanded and formed inside the pontoon shell; or (2) manufactured in large monolithic blocks such that the foam fits tightly inside the pontoon shells with a minimum of air gaps. In the case of concrete pontoons, the concrete is cast around a pre-manufactured foam core. In the cases of closed-vessel roto-cast polyethylene and fiberglass pontoons, the foam must be expanded inside the completed pontoons in precisely determined quantities. Too little foam will be ineffective if the pontoon leaks. Too much foam and the pontoon will be destroyed from the internal pressure from the expanding foam. The filling of pontoon shells with used foam debris and left over pieces is unacceptable.



Roto-Cast Polyethylene Foam-Filled Pontoon



Dock Sections with Polyethylene Pontoons

C6.5 Exposed foam pontoons will not be approved for use on marina projects.

Pontoons made exclusively with polystyrene or polyurethane foam, without protective shells, are subject to the dissolving effects of hydrocarbons such as gasoline and oil. Obviously, such exposed foam pontoons should never be used near fuel docks. Also, exposed foam is subject to mechanical wear from debris in the water, and damage from gnawing animals such as muskrats and other salt seeking rodents. The foam inside pontoon shells is the only insurance against a marina sinking. The foam must be protected.

C6.6 Where polyethylene pontoons are used, it is recommended that the following guidelines be used in the specifications:

- Method: Roto-Cast
- Material: Linear Low Polyethylene
- Nominal Wall Thickness: 0.150 inches
- Color: Black

C

C6.7 Where concrete pontoons are used, the walls, bottom and top act as a closed pontoon shell and a structural frame. They are very rigid, heavy, and provide excellent docks in relatively quiet marina basins. They probably should not be considered for marinas in open water locations subject to wave heights over 12-14 inches unless designed and built to also act as a wave attenuator.

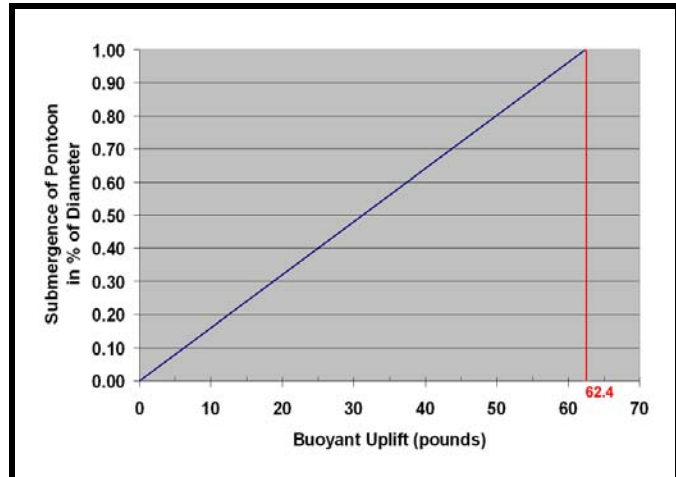

Rectangular Pontoon Loading Curve
Based on a 1 ft³ Pontoon, 12"x12" by 12" Long

C

C6.8 The loading characteristics of a pontoon are dictated by the vertical cross section. Both rectangular and circular pontoons are used for flotation.

C6.8.1 Rectangular pontoons with essentially vertical side walls, load in a linear straight-line fashion. As each increment of applied load sinks a pontoon deeper into the water, the pontoon responds with a proportionally increasing pontoon buoyant uplift.

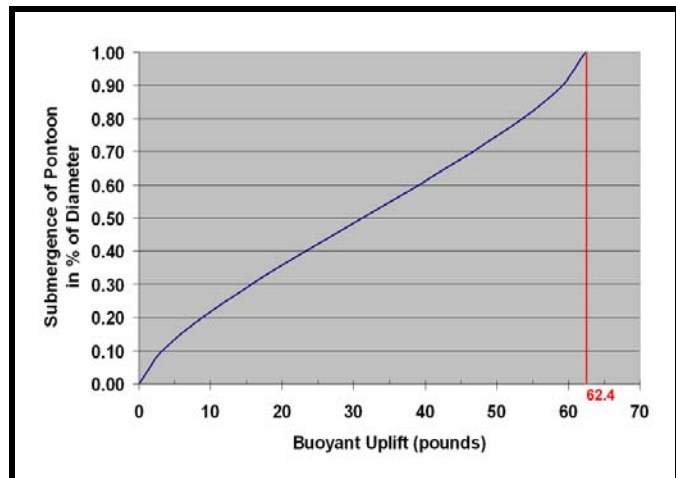

Circular Pontoon Loading Curve
Based on a 1 ft³ Pontoon, 13.54" Diameter by 12" Long

C6.8.2 Circular pontoons load in a non-linear fashion. As each increment of applied load sinks a circular pontoon deeper into the water, the lower half of the diameter responds with a disproportionately greater buoyant uplift, and the upper half responds with a disproportionately lesser buoyant uplift.

C7. Decking

Decking is the element in a marina berthing system that is probably most important to boaters. They don't much care what kind of pontoons are used or how big utility conduits are. But the decking is something they walk on, sit on, roll their carts over, sweep, hose off, and either love or hate depending on how it functions.

C7.1 Decking can be attached to a structural frame, or it can be part of the structural frame as in the case of cast concrete floats. Decking used in marinas includes various types of wood, pressure treated or untreated; recycled plastic lumber products; metal extrusions; fiberglass; and concrete.



C7.2 Marina decking should be oriented so the "grain" runs across the primary direction of travel. Decking grain includes broom and brush finishes on concrete docks; gaps between lumber decking; and ridges, serrations, knurling marks and other traction enhancing elements imparted to extruded metal and plastic decking.

C7.2.1 The decking on an accessible route shall not have gaps wider than ½ inch, and the gaps must be perpendicular to the path of travel to the maximum extent possible.



C7.2.2 Changes in decking level up to ¼ inch maximum shall be permitted to be vertical. Changes in level between ¼ inch and ½ inch maximum shall be beveled with a slope not steeper than 1:2.

C7.2.2.1 Where a change in level greater than ½ inch cannot be avoided, it shall be ramped at a slope not to exceed 1:12, with smooth transitions at the top and bottom of the ramp.

C7.3 Lumber (wood) decking should be oriented laterally, across the width of a dock, and never longitudinally, along the length of a dock. This applies to marginal walkways, main walkways, fingerfloats, and gangways as well. Torsional twisting will gradually break the fasteners on the butt ends of longitudinal decking, allowing opposing corners to raise up and cause tripping hazards. Lateral decking is perpendicular to the torsional axis and is essentially neutral to the torsional effects.



C8. Moorings

C8.1 The use of moorings is an alternative to berthing in certain circumstances, and may be used in lieu of or in conjunction with berthing. Mooring considerations include the wave climate; wind exposure; water depth; bottom conditions; ease of maintenance; management of the moorings; proximity to docks, berthing, channels and commercial shipping lanes; and environmental permit requirements.

C8.2 Moorings for recreational boats typically consist of buoys, chains or lines, and anchors connected together as a mooring system. The chain or line that connects a buoy to an anchor has historically been referred to as a **rode** which is an archaic past participle of the word **ride**. A boat tied to a mooring or an anchor can **ride** out a storm on a **rode**. Current terminology for moorings frequently refers to buoys, rodes and anchors.

C8.3 Recreational boat moorings typically consist of one of two types:

- fore and aft moorings
(two-point moorings)
- swing boat moorings
(single-point moorings)

C8.3.1 Fore and aft moorings are used to secure a boat from both the bow and stern, using various arrangements of buoys, rodes and anchors. The illustration to the right shows a mooring buoy (for bow line), a pickup buoy (to retrieve stern tie rode), rodes and two anchors. Once secured, boats will not swing with changes in currents, tides and/or winds. These moorings work well in waters with confused wave climates and currents that would cause adjacent moored boats to react in different ways, and perhaps collide with each other when secured to a single-point mooring. They also work well in coves and small bays with restricted water surface areas. Boats can be secured in well defined rows that can be oriented to the best advantage of boaters entering and exiting the mooring area. These moorings also allow more boats per acre of water surface as compared with swing boat moorings. An example of these moorings can be seen in operation in Avalon Harbor at Catalina Island.

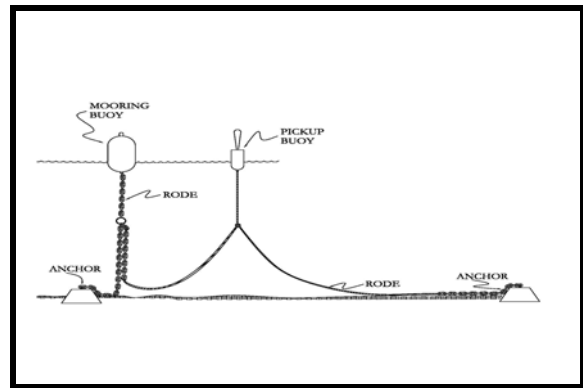

Fore & Aft Mooring

C

C8.3.2 Single-point swing moorings enable a boater to secure a boat, utilizing a single buoy, rode and anchor. A boat is secured to the buoy with a bow line, and is free to “swing” 360° on the mooring in response to the influences of wind, tides and currents. These moorings are less expensive than fore and aft moorings, and work well in locations where all moored boats can be expected to consistently swing in the same direction under all predictable

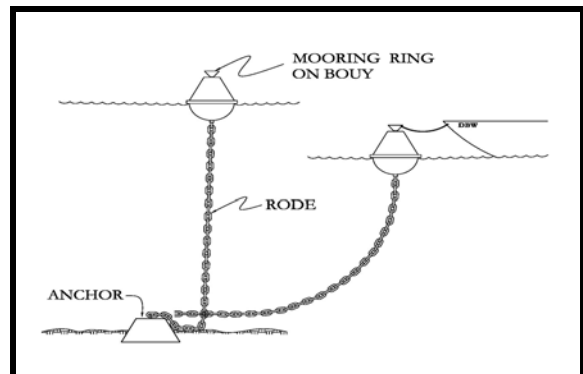

Single-Point Swing Mooring
Shown at Two Water Levels

circumstances. Swing moorings work well in open water areas where adequate space can be provided between adjacent moorings. They do not work well in locations where cross currents occur, or where currents and winds occur in conflicting directions, causing moored boats to swing into each other.

C8.4 Design Considerations

C8.4.1 The scope of the rode is the ratio of its length to the depth of the water, typically measured at maximum high water. Therefore, a mooring with a 5:1 scope will have a rode five times greater than the high water depth, including any waves that can be expected to occur.

C8.4.1.1 As the scope increases, the forces applied to the anchor become essentially horizontal, usually making the anchor more effective and resistant to being dragged. However, this is influenced by the characteristics of the rode, including material, weight and length.



C8.4.1.2 Many moorings are put together using a combination of materials in order to utilize the best characteristics of each material. In deeper waters, the weight of the rode becomes increasingly problematic. The mooring buoy not only has to function as the connecting link with a moored boat, but has to be large enough to have the buoyancy capacity to support the weight of the rode at maximum water depth. The heavier the rode, the larger the buoy.

C8.4.1.3 An option is the use of an elastometric mooring system that utilizes elastic rodes that stretch and contract under increasing and decreasing loads. This system will enable the rode to stay up off the bottom, and acts as a shock absorber for a moored boat. The design capacity of a mooring is directly related to the maximum size of boats to be moored and the site conditions. The elastic rodes can be single elements, or ganged together to provide the required design capacity.

C8.4.2 Mooring buoys should be highly visible, large enough to support the weight of the rode, strong enough to hold a moored boat of a predetermined size and weight, fitted with a mooring ring for securing a boat, and have sufficient surface area for identification numbers and instructions as required. Mooring buoys are typically made of fiberglass or polyethylene, and should be highly resistant to ultraviolet exposure, and foam filled to insure continued buoyancy in the event of puncture by boats, equipment, spear guns and bullets. Mooring buoys are commonly white in color and have reflective color bands and letters or symbols that conspicuously reflect light at night. Mooring buoys require maintenance and cleaning on a regular basis. They often become resting perches for gulls and other shore birds that defecate on the mooring rings and obscure identification and information markers.

C8.4.2.1 Mooring buoys should be clearly marked to identify the

maximum size and type of recreational boat that can be safely moored at specific buoys. If there are currents present, the drag on moorings from deeper draft vessels will be greater than from more shallow draft vessels. Sailboats will respond differently than powerboats. This is important not only for the owners of moored boats, but for others as well who may be moored nearby or underway, especially at night. In coastal waters where commercial shipping lanes may be nearby, these safety issues are of even greater importance for all concerned.

C8.4.3 Anchors used for boat moorings are many and varied, including concrete blocks, heavy recycled metal objects, mushroom anchors, piles, steel anchors with flukes, and spiral steel anchors that are literally “screwed” into the bottom. Some anchors function by virtue of their dead weight, some by their characteristics of holding to the bottom, and others by both dead weight and holding characteristics.

C

C8.4.4 Rafting (tying together, side by side) of two or more boats is something that can occur where moorings are used in conjunction with special events such as boat shows, opening day of boating seasons, etc. This is a social phenomena that is common among recreational boaters, particularly where mooring space or dockage is insufficient for the short-term demand during an event. Rafting can also occur at side-tie docks, in rivers, canals and other places where large numbers of boats congregate.



C

Boats Rafted on River Bank

C8.4.4.1 Where rafting is likely to occur, it should be addressed in one of two ways, or both, as follows:

- Local authorities should make and manage operational policies on the rafting of boats on available moorings. If not allowed, the operational use of the moorings should be monitored and enforced, and the moorings marked accordingly.
- If rafting is allowed, the moorings should be designed, installed and operated with some predetermined maximum rafting load in mind such



Extreme Rafting of Boats Across a River

as a two, three or four-boat maximum rafted mooring load. This will have an important bearing on the minimum sizes and capacities of the buoys, hardware, connections, mooring rodes and anchors. It will also have a bearing on the assessment of the bottom conditions and its capacity to hold various types of anchors under the design loads anticipated. The moorings approved for rafting should be marked accordingly, including the maximum size and number of rafted boats permitted.

C8.4.5 Moorings should be fabricated of highly corrosion resistant materials that will stand up in wet environments over a long service life. The extra expense of using stainless steel, bronze, fiberglass and polyethylene materials will more than be balanced by the reduced maintenance costs. However, corrosion resistance must not be provided at the expense of strength and toughness. For example stainless steel hardware for some of the connections may not be strong enough for the applied design loads. Galvanized steel parts may be a more feasible and reasonable alternative. The selection of proper materials is critical to a well functioning and long lasting mooring system.

C8.4.6 It is imperative that mooring systems be inspected and maintained on a regular scheduled basis. The boating public should be confident that moorings used are completely adequate for the size boats being moored, and that the moorings will function safely and reliably under all reasonable conditions for the site. Maintenance should include annual raising of the anchors, rodes and buoys for visual inspections, repairs and/or replacements.

C8.5 Connections

C8.5.1 All connections on a boat mooring should be of high reliability and trustworthy for public use. Moment developing connections should be avoided to prevent repetitive twisting and bending of mooring components that would lead to fatigue and eventual failure. A maximum degree of freedom should be provided at each connection through the use of a clevis, swivel, connecting links and/or short lengths of chain.



C8.6 Environmental Considerations

C8.6.1 As the scope of a mooring increases, the length of the rode increases as well, resulting in a progressively larger potential area of disturbance of the bottom. A swing boat mooring has a 360° circular potential area of disturbance with the anchor at the center. As winds and currents change direction, the buoy and a moored boat swing the rode, possibly creating and maintaining a disturbed circle on the bottom. All of this is dependent on the depth of the water, and the type and length of the rode. In the case of fore and aft moorings, the egg-shaped area of potential bottom disturbance is much smaller, being limited to lateral movement allowed by rode length and water depth. Site conditions will dictate which type of mooring is appropriate, safe and reliable.

SECTION D

GUIDE PILES

D1. General.

Marina guide piles must be provided at appropriate locations and in sufficient numbers to reliably retain a floating dock system in place under all design loadings, conditions and circumstances. It is important to determine in advance exactly what these factors are for a given site. Unusual and unanticipated events may occur that are beyond the design parameters. In such cases, failures may occur. However, to “over” design and build a marina beyond what is prudently called for at a given site may not be financially and economically feasible.

- D1.1 Consideration must be given to pile loadings from forces applied to the floating berths, guide piles and the boats occupying the berths. These forces include wind, waves, currents, seiche, flood flows, impacts from boats underway, debris, partially sunk boats, and seismic events. Some of these forces may occur concurrently.
- D1.2 Particular care must be given to seismic design in active earthquake regions. The type, weight and length of piles are very important in addressing seismic movements in a marina, as well as the soil characteristics of the bottom of a marina basin into which the piles are driven.

D2. Design Criteria.

D2.1 Marina guide piles should be placed at the ends of all fingerfloats adjacent to channels. The piles will help guard against accidental impact damage to docks and berthed boats from vessel traffic in the channels. Such impact incidents can be caused by severe wind conditions, currents, traffic problems and/or boat operator error.



Fingerfloat Piles Adjacent to Channel

D2.2 Mooring piles are sometimes provided in double berths over 36 feet long. Used to secure additional boat lines, they help to keep a moored boat away from the edge of the docks, thus reducing wear on both the boat and docks. They also provide protection to a boat berthed in one side of a double berth from another boat entering or exiting the other side.

C

D2.2.1 Where funding is limited, double berths are sometimes provided with the intention of converting them into single berths at a future date when funds become available. As an interim measure, a mooring pile is sometimes provided in the center of a double berth, in lieu of a fingerfloat. This all depends on the relative costs of providing a fingerfloat versus a pile. Under such a plan, the required width of two single berths plus the width of the future fingerfloat must be provided for in the marina layout plan. Short-sighted planning may not include the width of the mooring pile or a future fingerfloat, meaning the two future single berths will be too narrow for their length. If a mooring pile is provided, and a future fingerfloat is installed, the mooring pile will either have to be removed, or utilized to secure the end of the future fingerfloat, depending on the fingerfloat length.



Mooring Pile in Double Berth

D2.3 Cut-off elevations for guide piles should be not less than 4 ft above the deck of a floating dock at design high water, not including the height of pile caps. This means that the top of a guide pile will be not less than 4 ft + the dock freeboard above the water line at design high water. Such cut-off elevations should be determined using maximum freeboard under DL only, and will typically be around 6.5 ft above design high water.



D2.4 Guide pile caps should be provided, typically made of fiberglass, polyethylene or other ultraviolet resistant plastic materials. Pile caps discourage the roosting of birds, can be color coded to identify particular fairways or channels, and are useful for mounting various marina operation devices such as signs, markers, antennas, video cameras, etc.



Pile Cap and Marker Signs

D3. Material Pile Types.

Marina guide and mooring piles are typically concrete, steel, composites or wood. Such piles are utilized primarily to resist lateral loads from docks and moored boats, and are available in square, round and/or octagonal cross sections, depending on the material and manufacturing process. Bearing piles for supporting buildings, fishing piers, etc. are not addressed in these guidelines.

D3.1 Concrete Piles. Prestressed concrete piles are probably the most common marina guide piles used in marinas. They are available in square, round and octagonal cross sections, in lengths up to 120 feet. The practical use of the longer concrete piles is typically limited by transportation of the piles to a project site, safe handling of the piles, and the size of the pile driving equipment available.



Square Concrete Guide Pile in River Marina

D3.1.1 Precast concrete piles are available in lengths up to 50 feet. They are steel reinforced but are not as strong and durable as prestressed concrete piles. Non-prestressed precast concrete piles are not recommended for use as marina guide piles.



D3.1.2 Square concrete piles are usually less expensive, and work well with square pile yokes and roller systems. However, square piles tend to rotate during driving, often resulting in an unattractive appearance and problems with the pile yokes and rollers. Piles that have rotated even a few degrees during driving can cause expensive delays and modifications during construction, and long term maintenance problems. If square piles are used, great care must be taken to insure that the final orientation of the piles is square with the docks.



D3.1.3 Round concrete piles are considered more attractive than square piles, and are the easiest to drive with regard to rotation and appearance. However, round concrete piles are not often used because (1) they are more expensive than square concrete piles, (2) their production is presently limited to a rather small number of casting yards, and (3) transportation costs prohibit long distance deliveries.

D3.1.3.1 Where pile rollers are used with round piles, the rollers tend to wear thin in the middle as they progressively conform to the round shape of the pile. However, this arrangement can give long reliable service unless excessive lateral movement occurs between the pile and roller, a dynamic action that can quickly ruin the rollers.



Round Concrete Piles on a Barge

D3.1.3.2 Spun concrete piles are currently made in Australia and will probably soon show up in United States markets. Spun inside a long

spinning pipe mold, the piles have a hollow core, high strength, are very flexible, and weigh less than conventional concrete piles of the same diameter. The length of such piles is limited by the same factors as conventional piling: ease of handling, transportation, ease of access to the site, and availability of pile driving equipment.

D3.1.4 Octagonal concrete piles offer a good compromise between square and round concrete piles. They appear to be round from short distances, keeping a good appearance even if they rotate during driving. The flat faces provide good bearing for pile rollers and help extend the service life of the rollers. If pile rotation occurs during driving, the pile yokes and rollers must be justified to the pile as with square piles. The faces of octagonal piles act as chamfered surfaces with chip resistant vertical edges that are reasonably user friendly to hands and equipment of boaters and maintenance staff. Octagonal concrete piles typically are more expensive than square piles of the same nominal dimensions.



Flex Testing Spun Concrete Pile

D3.2 Steel Piles. Steel piles are typically round in cross section, and are available in a variety of diameters, thicknesses, lengths and alloys. Structural steel tubing may sometimes be used as square piling in sizes up to 12 inches for special applications.

D3.3 Wood Piles. Wood piles have round cross sections by virtue of the natural shape of the trees from which they are made. Sizes range up to 100 feet in length with diameters from 10 to 36 inches. The larger sizes are very expensive, and shipping costs can be prohibitive. Wood piles in longer lengths will rarely be perfectly straight, so very specific tolerances must be specified in order for wood piles to work properly in pile yokes at various water levels. Also, the same roller problems will occur on round wood piles as with round concrete and steel piles.



Steel Guide Piles in a River Marina

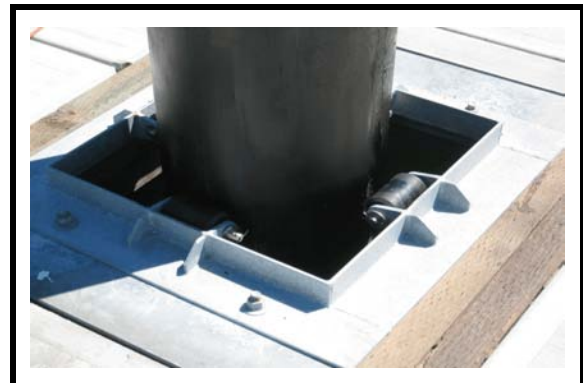

Rollers on Round Steel Guide Pile

C

D3.3.1 Pressure treatment is necessary to protect wood piles against rot, decay and various organisms in the water that eat and destroy untreated wood. This is particularly true in warm, clean, salt water environments in which marine organisms are vigorous and healthy. Wood piles must be pressure treated with a preservative approved for use in local waterways. Untreated wood piles should never be used for marina piles.

D3.3.2 Although the use of pressure treated wood piles in marinas has diminished over the years because of environmental water quality laws and regulations, there are still applications in which a wood pile is highly appropriate. Where larger boats use landings, fuel docks and sewage pumpout stations in waterways subject to surge, currents, floods, floating debris and other lateral loadings, flexible wood piles can be very beneficial in acting as shock absorbers, lessening possible damage to both the docks and the moored boats. However, if allowed to be over stressed, wood piles will crack or break. Under sever flood conditions in rivers, for example, a series of wood guide piles may snap consecutively if subjected to sudden and/or sustained lateral loads that they are not capable of withstanding. See Section C2.5 regarding environmental loadings.

D3.4 Plastic Piles. Plastic piles are manufactured of commercial grades of high density polyethylene plastic reinforced with steel rods, cables or pipes imbedded in their core for added strength and resistance against warping. Such piles are quiet compared to steel or concrete piles when boats, boat masts, rigging and/or other equipment bangs against them during windy weather and storms. They also are very smooth, enabling pile yokes to easily work against them with little friction.

D3.4.1 Plastic piles must be handled and driven with care to prevent cracking. They are flexible and must be protected from excessive bending when shipped, handled and driven. Cracks in plastic piles may not be evident at the time the cracks occur. Typically being black in color for ultraviolet protection and appearance, cracks may be hard to see until months after driving has been completed and the piles are in service. If cracked, the cracks will gradually widen from thermal expansion and contraction, and bending from applied loads. This will gradually allow water to enter the cracks and begin rusting the interior steel reinforcement, slowly breaking down the bond between the plastic and steel. This is particularly troublesome in salt water applications. Plastic piles have also been used for fender piles on large commercial ship piers.

SECTION E

UTILITIES

E1. Utilities on Shore

E1.1 Utility lines on shore should be located underground as is appropriate, and to the extent reasonably possible and financially feasible. Such utility lines include potable water, fire suppression, electrical power, telephone, cable TV, Internet, lighting, security systems, aids to navigation systems, natural gas, sanitary sewer and drainage. Utility sizing, location, design and construction must conform to accepted industry practice and all applicable codes and regulations.

E1.2 Landside utilities should be located, designed and installed with consideration given to practical uses of the marina facilities after construction is completed. Utility planning should provide reasonable access for future maintenance, repair, replacement or expansion of utility lines without major disruption of normal marina functions.

E2. General -- Utilities in Marina Berthing Structures

E2.1 All utility lines in marina berthing structures should be installed to provide maximum public safety as well as protection from impacts, mechanical wear and damage, and environmental elements such as heat, water and rodents.

E2.2 Utility sizing and capacity should be determined on the basis of current and projected use demands, anticipating future levels of service and how to reasonably provide it if necessary.

E2.3 No permanent utility lines should be located on and attached to the deck surface of marina docks. Electrical outlets, water supply hose bibbs, and TV jacks are usable only with lines, cords and hoses that are connected between utility boxes and berthed boats. However, they are temporary in nature and function, and should not be permanently attached to the deck surface.



Non-Permanent Utility Lines Across Fingerfloat

E2.4 It is desirable that all utility lines in a floating dock system have not less than 6 inches minimum clearance above the

C

water surface under DL only, and not less than 2 inches clearance under DL + ULL + LPL. Depending on the type of dock system, if utilities are placed high within the dock structure, these minimum clearances should not be difficult to meet.

E2.5 Where utility lines pass through structural members within a floating dock system, the holes in the structural members are to be free of rough edges and abrasive surfaces that will cause accelerated wear on the utility lines.



E3. Potable Water Service on Marina Docks

E3.1 Each potable water line should deliver water to all hose bibbs at a water pressure not less than 35 psi while 10 percent of the hose bibbs are fully open and running. This level of service will meet normal water demands, and help guard against unusually low water pressure during weekends and holidays.

E3.2 ***All potable water lines on marina docks shall be equipped at the shore end with appropriate anti-siphon devices to prevent back flows into the service mains.***

E3.3 A minimum of one (1) standard 3/4 inch hose bibb is to be provided for each berth. ***Each hose bibb shall be fitted with an anti-siphon device to prevent back flows into the supply line.***



Storage Box with Anti-Siphon Hose Bibb

E3.4 Dedicated potable water and fire suppression lines should be provided on marina dock systems. Potable water and fire suppression lines should not be combined.

E3.5 Where risers and hose bibbs are not located on both sides of a fingerfloat, it is acceptable for a water hose to be laid across the width of a fingerfloat to provide potable water to a boat in a berth on the opposite side from the riser and hose bibbs, ***except on accessible berths*** (see E3.7 below).



E3.6 ***Utility hoses and/or lines, whether permanent or temporary, shall not be allowed across the deck of main walkways or marginal walkways.***

E3.7 ***Where a fingerfloat is part of an accessible route, utility hoses and lines shall not be allowed across the fingerfloat.***

E4. Fire Suppression Systems on Marina Dock Systems

E4.1 It is required that marinas have equipment, systems and sustainable water resources to suppress, control and extinguish fires on boats, docks, buildings,

fueling stations and other marina service centers. It is recommended that the local fire marshal be included in all stages of marina design for both new and alteration projects. This will help ensure that all code requirements are addressed, and will facilitate the smooth and effective inspection and completion of projects.

E4.2 Marina fire protection systems fall into one of the two following types:

Low Volume, Low Pressure -- Emergency First Aid Capability

This type typically consists of a series of fire hose cabinets strategically located on a marina, supplied by lines that deliver water at working pressures up to 60 psi, fire flow rates of 40-60 gpm, and nozzle exit pressures of not less than 40 psi.

High Volume, High Pressure -- Major Capability

This type typically consists of water lines and fire hydrants with working pressures up to 200 psi, and fire flow rates of 500 gpm and up, depending on the length of the lines, and the number and spacing of the fire hydrants.

E4.3 It is recommended that fire lines be dedicated lines, and not connected with potable domestic supply lines on floating docks. This will give greater integrity to the fire lines, and increased control of the water supply in the event of a fire. It will also help guard against cross contamination of water lines from line failures, pressure reductions and/or back flows.

E4.4 Fire lines must be fabricated from materials that will stand up under the required working pressures and temperatures, and be corrosion resistant in a wet environment.

E4.4.1 All pipe fittings and valves used must have a pressure rating not less than the pipe itself. For example, 150 psi rated fittings are sometimes used on 200 psi rated pipe. This will not work on a high pressure fire line if the higher pressures can actually occur during system tests and/or actual fires.

E4.4.2 All pipe, fittings and valves must be of a material that will not soften from the heat of a fire, rupture and/or otherwise fail while being used to fight a marina fire. Therefore, such materials and components must be certified for use in working temperatures as per the local fire marshal.

E4.4.3 All pipe, fittings and valves must be highly corrosion resistant, particularly in coastal marinas subject to salt water and salt air corrosion.

E4.5 Where sharp bends occur in fire lines, restraints must be installed to stabilize the pipe and diminish movement resulting from sudden pressure changes, expansion, contraction and water hammer from valve closures.

E4.6 Fire lines must be located below the marina deck on both low and high pressure systems. This will protect the fire lines from impacts, vandalism, or other

damage that would diminish or destroy utilization of the lines during a fire. Placing fire lines below the deck also protects the public from potential personal injury in the event of a serious high-pressure leak, or a sudden pipe or fitting failure.

E4.7 All fire lines in marina dock systems must be equipped at the shore end with appropriate anti-siphon devices to prevent back flows into the service mains.

E4.8 Where low pressure fire lines and fire hose cabinets are provided, the cabinets are to be located at appropriate spacings and locations to afford immediate protection to all floating structures, boats and equipment in a marina. The spacing should be such that a charged fire hose will be able to reach the outboard end of each fingerfloat in a marina. This level of fire protection is generally understood to be “first aid” fire fighting capability. Marina designers must check with local fire officials and make appropriate provisions for major fire fighting capability in accordance with specific needs and code requirements.

C

E4.9 The required number of fire hose cabinets per fire supply line will be determined on the basis of the marina layout; local, state and national fire codes; and determinations made by the local fire marshal.



Dock-Side Fire Hose Cabinet

E4.10 Where fire hose cabinets over 27 inches high are located on an accessible route, they shall have recessed handles and locks, and not protrude into the walkway more than 4 inches.

E4.11 Marinas are typically viewed by fire officials as being similar to buildings on shore with regard to the requirements for the provision and maintenance of a reliable clean water source, and high pressure water lines for delivery of water during a fire emergency. There are options in addressing these requirements.

E4.11.1 Charged standpipes will usually be 2½ to 4 inches in diameter, in continuous service at live working pressures up to 200 psi, and have fire hose connections at appropriate locations along the length of the lines. Such a system enables fire fighters to quickly address a fire, even if it is in a remote location in a marina. Where dock systems have long walkways that extend hundreds of feet out from shore, charged lines save the time and energy necessary to carry, roll and charge fire hoses connected to fire hydrants on shore. If it becomes difficult to maintain live working pressures up to 200 psi, an alternative may be to maintain lower pressures of up to 60 psi, which can be boosted by the fire department when needed. However, testing and operational readiness of the system must be maintained at the higher pressure service level.

C

E4.11.2 Dry standpipes have exactly the same characteristics as charged standpipes, except they are empty until needed. In the event of a fire, the local fire department hooks up a pumper truck to the dry standpipe, charges it to operating pressure, and uses it to deliver water to fight a fire. A dry standpipe system eliminates most of the weight and pressure problems experienced in a charged standpipe system.



E4.12 Drafting fire hydrants are sometimes utilized by waterfront agencies when reliable sources of domestic water are not available via normal water mains and municipal service lines. Water is “drafted” directly from the marina basin and pumped into the water lines for use in fighting a fire. However, a number of problems can arise from use of such a system, and the use of drafting fire hydrants should probably be a last resort option. A better option may be the provision and utilization of portable fire carts that can be taken quickly to any area on a marina. Such carts should be self contained and equipped with gasoline engine driven pumps, adequate hose lengths, locking wheels and foam suppression systems. They are available in a variety of types and sizes.



E4.13 Where fire lines and pipes pass through structural members within a floating dock system, the holes in the structural members must be free of rough edges and abrasive surfaces that will cause accelerated wear on the fire lines.

E4.14 At least one strategically located device for calling the local fire department should be located on the docks in a marina. In cases where a marina consists of two or more dock sections, or marina basins, at least one fire-call device should be provided in each section and/or basin.

E4.15 Marina fueling stations located on marina docks should be equipped with a fire-call device, such as an emergency fire call-box or non-coin operated telephone, located not more than 100 feet from the fuel dispensing equipment.

E4.16 Foam suppression capability should be considered as part of the overall plan for fire safety in new construction and alterations to existing marina facilities.



E5. Electrical Power Services on Marina Dock Systems

E5.1 Each marina developed or improved with loan funds from the Department of Boating and Waterways on or after January 1, 2002, shall have its over-water electrical systems inspected biennially, during the term of the loan, by a licensed electrical contractor or licensed electrical engineer, for compliance with the safety-related provisions of the California Electrical Code.



E5.1.1 If newly constructed, an inspected marina shall comply with all of the California Electrical Code requirements in effect at the time the marina was developed.

E5.1.2 If a marina is improved, the areas of the marina in which electrical improvements were made shall comply with the California Electrical Code in effect at the time of the improvement.

E5.1.3 For the purposes of these required biennial inspections, a marina is a boating facility that meets the following criteria:

- owned and operated privately, or by a local governmental entity;
- consists of seven (7) or more berths; and
- is used by the public primarily for recreational purposes.

E5.2 In addition to the required biennial electrical inspections in E5.1, it is highly recommended that ground integrity testing be performed at least annually in all marinas. The importance of this cannot be overemphasized as it is a life safety issue. Where the electrical ground is compromised, situations can occur that lead to serious personal injury, death by electrocution, and electrical shock drowning. Ground integrity testing can be accomplished with appropriate plug-in testers that confirm the integrity of the ground as well as the polarity of the outlet. The cost of this testing is not prohibitive, and cannot be compared with the exposure to possible tragedy to boaters and marina staff.

E5.3 Marina electrical systems should be adequate to supply the power demands for boat slips, lighting, fuel stations, sewage pumpout stations, buildings, navigation aids, and maintenance and repair work.

E5.4 Accessible utilities in a marina, including electrical power outlets and jacks for telephone and cable TV, shall have unobstructed access, and meet the following reach range heights, measured vertically from the dock surface:

Forward Reach:	15 inch minimum	48 inch maximum
Side Reach:	15 inch minimum	54 inch maximum

E5.5 It is recommended that a minimum of one (1) 120 volt 20 amp outlet be provided at each boat berth, regardless of the length of the berth or the boat that occupies it. Keep in mind this is a minimum recommendation, and that identified site specific power demands may be well above this minimum recommendation.



E5.6 Ground fault circuit interrupters (GFCI) are not required by the NEC on receptacles that supply shore power to boats located at marina berths, wharfs, piers and other similar boating facilities.

E5.7 It is not recommended that GFCIs be provided on electrical outlets for individual boat berths. To do so may invite some or all of the following problems:



- nuisance tripping of the devices
- emotional friction between marina staff and boat owners
- false sense of security
- unnecessary increases in operation and maintenance costs

E5.8 It is highly recommended that dedicated 120 volt 20 amp GFCI power outlets be provided on marina docks for use by maintenance staff. Such dedicated outlets should be provided at logical locations for this purpose, and are required by the NEC to be equipped with GFCIs.

E5.9 Sub-metering of marina electrical outlets is highly recommended. The installation and use of kilowatt hour sub-meters in marinas has a dramatic positive impact on the reduction of electrical power consumption.



E5.9.1 One of the primary requirements is the provision that sub-meters must be located within the vertical range of 30-75 inches, measured from the deck surface to the axis of the sub-meter. The primary purpose for this requirement is to provide safe and adequate access for persons who are required to calibrate and maintain the sub-meters.

E5.10 Marine grade electrical outlets designed and manufactured for reliable use in fresh and salt water environments are to be used to provide electrical power to boat slips. Lower quality electrical equipment manufactured for buildings and dry environments do not function well in marinas.

E5.11 Electrical outlets are often installed in dock storage boxes or electrical power centers located along the edge of walkways and at the head of fingerfloats. The dock storage boxes are also often fitted with potable water supply hose bibbs and jacks for telephone and cable TV service. It is recommended that water supply and electrical services not be installed in the same dock storage box. Storage boxes can be damaged by high winds, impacts from boats entering a boat slip, and impacts from heavy carts being moved on the docks, any of which can result in broken water lines. Water and electrical power in the same storage box is inadvisable.



E5.12 From the electrical outlets, power is supplied to a berthed boat via a portable electrical cord that extends between the outlet and a boat. The portable cord is usually stored on the boat when not in use. Such cords should be rated for this use, including proper plug type, wire size and cord length. A boat in a berth must be tied up such that the normal movement of the boat within the berth will not pull, jerk or damage the outlet, electrical cord or the boat's electrical system.

SECTION F

SHORELINE STRUCTURES

F1. Piers

F1.1 Piers that are used only for pedestrian access to gangways and floating docks should be designed to support a minimum ULL of 50#/ft². This is equivalent to the required loading for vehicle storage garages, fixed seating areas and offices, and is the same ULL required on gangways.

C

F1.2 **Guard railings shall be provided on all piers which are more than 30 inches above grade.**

F1.2.1 **Height of the top rail of guard railings shall be not less than 42 inches, measured from the finished deck surface to the top of the top rail, except on fishing piers as addressed in F1.2.2.**

F1.2.2 Fishing is typically not allowed from piers within marinas because of potential conflicts between anglers and boaters, and local regulations that may prohibit fishing within marina basins. However, **on an accessible pier where fishing is allowed, 25 percent of the railing must have a maximum top rail height of 34 inches for anglers with disabilities fishing from benches, stools or wheelchairs.**

F1.3 **Openings in guard rails shall not permit the passage of a 4 inch diameter sphere.** This can be accomplished by use of intermediate rails, pickets and/or ornamental components.



Guard Rail w/Hand Rail Meets 4" Sphere Test

F1.4 A minimum design load of 20#/linear foot should be applied horizontally along the centerline of the top rail of all guardrails.

F1.5 Handrails must be provided where a pier is part of an accessible route, and must be not less than 34 nor more than 38 inches above the walking surface, measured to the top of the handrail. In cases where fishing is allowed, the top rail will be both a guardrail and a handrail throughout the 25 percent of the rail length that is lowered as per F1.2.2 above. These lowered sections of railing are to be dispersed throughout the length of the railing where fishing is permitted.

F2. Gangways

F2.1 From an emergency exit standpoint, it is desirable to have a minimum of two gangways serving a marina, or an individual section of a marina that is not accessible from other marina sections served by a gangway(s).



F2.2 Uniform Live Loads

100 #/ft² minimum ULL shall be used for gangway structural design.

50 #/ft² minimum shall be used for ULL transferred to floating docks.

F2.3 Loadings transferred from a gangway to a floating dock system include appropriate portions of both the gangway DL and ULL.



F2.4 Recommended minimum clear gangway width is 36 inches. Anything less is impractical in consideration of typical gangway traffic and transfer of goods, supplies and equipment.

F2.5 ***Minimum clear width of a gangway on an accessible route shall be 36 inches.*** This includes the clear width between handrails on each side of an accessible gangway.



36" Minimum Gangway Width

F2.6 Gangway Railings

F2.6.1 Guard Rails.

F2.6.1.1 Guard Rail Loadings.

50#/linear foot applied horizontally along centerline of top rail

200# LPL applied vertically at any point along length of any horizontal guard railing, including the top rail and any mid-rails

F2.6.1.2 Guard Rail Heights.

42 inches minimum height
45 inches maximum height

measured perpendicular from deck to top of top rail

F2.6.1.3 **Openings in guard rails shall not permit the passage of a 4 inch diameter sphere.** This can be accomplished by use of intermediate rails, pickets and/or ornamental components.

F2.6.2 Handrails.

F2.6.2.1 **Handrails shall be provided on both sides of all gangways.**

F2.6.2.2 Handrail Heights.

All heights are to be measured perpendicular to gangway deck.



Minimum Height:
34 inches

Maximum Heights:

35¼ inches on gangways not exceeding a 2½:1 slope

36 inches on gangways not exceeding a 3:1 slope

38 inches on gangways not exceeding a zero slope

F2.7 Gangway decks must have a durable non-skid surface to provide traction, especially when wet, and when gangways are at steeper slopes.



F2.8 The use of cleats on gangway decks to improve traction is generally to be avoided. However, where gangways remain at steep slopes for long periods of time, gangway cleats may be deemed necessary to develop improved traction.



Handrails on Both Sides of a Gangway

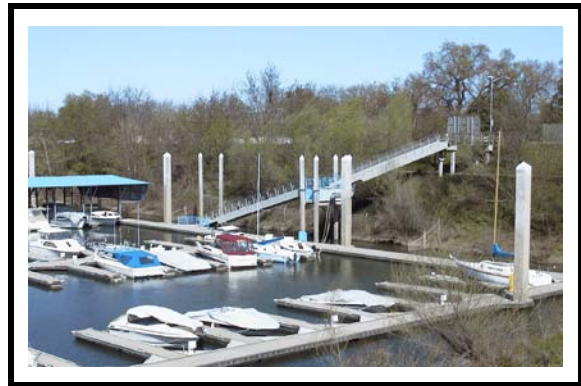

Steep Gangways at River Based Marina

F2.8.1 Gangway cleats should meet the following criteria:

- be attached perpendicular to the long axis of the gangway
- spaced on 12 to 16 inch centers
- maximum width of 1 inch
- maximum height of ½ inch
- if greater than ¼ inch high, all edges above ¼ inch to be beveled at 45°

F2.8.2 Gangway cleats shall not be used on accessible gangways.

F2.9 Maximum gangway slopes.

F2.9.1 On Coastal Waterways:

- 3:1 maximum slope @ 0.0 MLLW or above
- 2½:1 maximum slope below 0.0 MLLW



F2.9.2 On Inland Waterways:

- 3:1 maximum slope not less than 90% of the time
- 2½:1 maximum slope not more than 10% of the time



F2.9.3 Accessible Gangways on both Inland and Coastal Waterways:

- 1:12 maximum slope (see exceptions below)

F2.9.3.1 The following two exceptions (numbers 3 and 4) apply to accessible gangway slopes. They are two of the eight exceptions that apply to accessible gangways. See F2.15.8 for the complete list of gangway exceptions.

Exception 3.

If the total length of a gangway, or series of gangways, is at least 80 ft, the 1:12 maximum slope does not apply.

Exception 4.

In a marina with less than 25 boat slips, and the total length of a gangway, or series of gangways, is at least 30 ft, the 1:12 maximum slope does not apply.

F2.10 Toe plates provided at either the lower and/or upper ends of a gangway, provide a smooth transition between the gangway deck surface and shore or a marina dock.

F2.10.1 The maximum toe plate slope is 3:1 under any in-service conditions or water levels. This applies to gangway toe plates on both coastal and inland waterways.



Toe Plate on Non-Accessible Gangway, or **Transition Plate** on Accessible Gangway

F2.11 Transition plates shall not under any circumstances exceed a slope of 1:12.

F2.12 Where the lower end of a gangway is supported on the deck of a marginal walkway or a main walkway, additional walkway width may be necessary to prevent

encroachment into the minimum clear widths of such walkways. The additional walkway width, if necessary, can be provided by a floating landing platform secured to the edge of the walkway. Care must be taken to maintain freeboard and cross slope requirements.

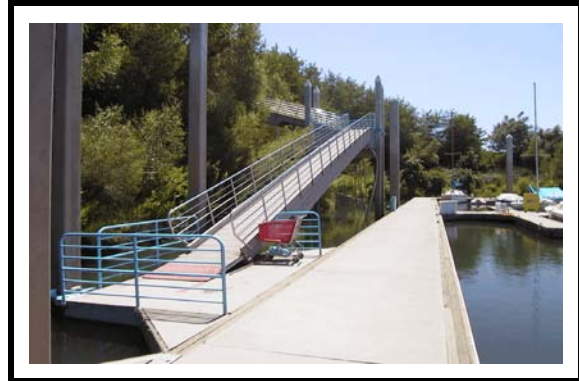

Floating Landing Platform for Gangway

C

F2.13 Gangway utility connections require careful design, installation and maintenance. Gangways function as utility bridges across the land/water interface, providing a flexible link

between shoreside and dockside utility lines as follows:

- electrical power
- telephone
- cable TV
- sewage lift-station
- potable water supply
- fire suppression
- fuel
- oil collection/discharge

F2.14 Accessible Gangways

C

F2.14.1 An accessible gangway is an element of an accessible route that links floating docks with walkways, piers, bulkheads, parking areas, buildings, and other accessible marina service and activity centers.

F2.14.2 An accessible gangway connects a fixed pier or abutment on shore to a floating dock or other floating structure in a marina, excluding gangways that connect to vessels (ferries, commercial ships, livery boats, charter boats, vessels for hire, common carriers, etc.).

F2.14.3 Newly designed, or newly constructed and altered marina facilities, including gangways, are required to comply with federal and state accessibility guidelines which apply to each newly designed or newly constructed marina facility.

F2.14.4 Altered marina facilities must conform to federal and state accessibility guidelines.

F2.14.4.1 An “alteration” consists of any change in a primary function that adds new services or features. Examples would be the addition of electrical outlets on berths not previously so equipped, the provision of new berths of a different length or particular characteristic, or the provision of a totally new feature such as a fueling station, pumpout facility, boat rental service, etc. Routine maintenance work such as the replacement of decking and other components does not constitute an alteration.

F2.14.5 Existing marina facilities not being altered are not affected by new federal guidelines for recreational boating facilities published in 2002, and updated and edited in 2004.

F2.14.6 Where an existing gangway (or a series of gangways that constitutes a single gangway system) is replaced or altered, an increase in the length of the gangway(s) is not required unless alterations are made to an area containing a primary marina function.



F2.14.7 Where there is a change in a primary function, and the cost of lengthening an existing gangway is considered to be disproportionate to the cost of overall alterations, the gangway does not have to be lengthened.



F2.14.8 By reference, an accessible gangway must comply with certain requirements for an accessible ramp, including location, width, passing space, head room, surface textures, slope, changes in levels, doors, egress and areas of rescue assistance. Since a variable slope gangway is significantly different in nature from a fixed slope ramp, eight (8) exceptions were provided in federal guidelines published in 2002, the first seven of which were carried over into revised guidelines published in 2004. See Appendix B for a side-by-side comparison of ADAAG Section 15.2 (published in 2002) and ADA-ABA Sections 1003 and 235 (published in 2004). The ADA-ABA guidelines are presently under review by the Federal Department of Justice.

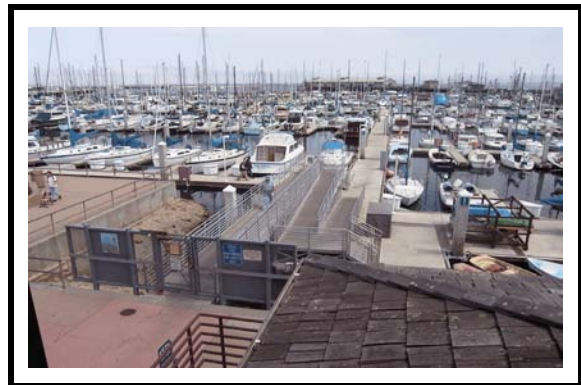

Security Gate, Gangway and Switchback Ramps

Exception 1.

Where an existing gangway or series of gangways is replaced or altered, an increase in the length of the gangway is not required to comply with 15.2.2 unless required by 4.1.6(2).

Exception 2.

The maximum rise of 30 inches for a ramp does not apply to an accessible gangway.

Exception 3.

Where the total length of the gangway or series of gangways serving as part of a required accessible route is at least 80 feet, the 1:12 maximum slope for ramps specified in ADAAG 4.8.2 shall not apply to the gangway(s).

Exception 4.

In facilities containing fewer than 25 boat slips and where the total length of the gangway or series of gangways serving as part of a required accessible route is at least 30 feet, the 1:12 maximum slope for ramps specified in ADAAG 4.8.2 shall not apply to the gangway(s).

Exception 5.

Where gangways connect to transition plates, landings at each end of ramps specified by 4.8.4 shall not be required at the ends of accessible gangways.

Exception 6.

Where gangways and transition plates connect and are required to have handrails, handrail extensions specified for ramps in 4.8.5 shall not be required on gangways. Where handrail extensions are provided on gangways or transition plates, such extensions are not required to be parallel with the gangway or transition plate surface.

Exception 7.

The cross slope of gangways, transition plates, and floating piers that are part of an accessible route shall be 1:50 maximum measured in the static position.

Exception 8.

Limited-Use/Limited-Application elevators or platform lifts complying with ADAAG 4.11 shall be permitted in lieu of gangways complying with 4.3.

SECTION G LAND AREAS

G1. Vehicle Parking

- G1.1 Types of marina parking spaces
- single-vehicle space
 - recreational vehicle space
 - vehicle/trailer space
 - recreational vehicle/trailer space

G1.1.1 Accessible spaces shall be provided for all of the above types of parking spaces that are provided in a marina, including van accessible parking spaces. Not all types of parking spaces will necessarily be provided at a specific marina.



Single Vehicle Accessible Parking Spaces



Van Accessible Parking Space



G1.2 Minimum Number of Single Vehicle Parking Spaces



G1.2.1 0.60 single vehicle parking spaces per recreational berth

G1.2.2 2.00 parking spaces per commercial fishing boat berth



G1.2.3 Accessible marina parking

G1.2.3.1 The parking levels shown in Table G-1 below are “minimum” requirements as set by federal and state guidelines. Higher levels of various types of accessible parking may be necessary to meet demonstrated local demands.

Table G-1 Minimum Number of Accessible Parking Spaces

Accessible Marina Parking		
Reference	Total Marina Parking	Minimum Required Accessible Spaces
ADA-ABA Section 208.2 ADAAG Section 4.1.2 (5) Title 24 Section 1129B	1 to 25	1
	26 to 50	2
	51 to 75	3
	76 to 100	4
	101 to 150	5
	151 to 200	6
	201 to 300	7
	301 to 400	8
	401 to 500	9
	501 to 1000	2 percent of total
	1,001 and over	20 plus 1 for each 100, or fraction thereof, over 1000

G1.2.3.2 The total minimum number of accessible parking spaces required need not necessarily be provided in a particular parking lot to which the table is applied. The accessible spaces for the particular parking lot may be provided in a different location if equivalent or greater accessibility is ensured in consideration of:

- distance from marina berthing facilities and other marina services;
- cost of construction, operation and maintenance; and
- overall convenience of the users.

G1.2.3.2.1 Marinas often have several parking lots around a marina basin. The flexibility to determine the best locations for accessible parking among various options can add to the quality of accessibility.

G1.2.3.3 ***One in every six (6), or fraction of six, accessible parking spaces, but not less than one (1), shall be designated “van accessible.” This applies to each type of parking provided.***



G1.3. Minimum Parking Space Dimensions

**Table G-2
Recommended Minimum Parking Space Dimensions**

Type of Parking Space	Width	Length
single-vehicle	9 ft	20 ft
recreational vehicle	11 ft	40 ft
vehicle/trailer	10 ft	40 ft
recreational vehicle/trailer	11 ft	55 ft

**Table G-3
Minimum Required Accessible Parking Space Dimensions
(Widths are Required)
(Lengths are Recommended)**

Type of Accessible Parking Space	<i>Widths</i>			Length
	<i>Parking Space</i>	<i>Access Aisle</i>	<i>Total Width</i>	
single-vehicle space	8 ft	5 ft	14 ft	20 ft
van accessible space	8 ft	8 ft	16 ft	20 ft

G1.3.1 As seen in the table above, the minimum width of the access aisle adjacent to all accessible parking spaces is 5 ft except for van spaces. All accessible van spaces must have access aisles at least 8 ft in width.

G1.3.1.1 An option to 8 ft wide access aisles adjacent to van accessible spaces is provided in ADA-ABA, now pending with the Department of Justice. If the parking space is 11 ft wide minimum, a 5 ft wide access aisle may be used.



G1.4 General Parking Space Design Criteria

G1.4.1 Location.

Marina parking areas should be located near the berths they serve. The proximity of parking to berths will usually be influenced by regulatory requirements and/or prohibitions, competition for land space from other waterfront users and activities, and site specific considerations.

G1.4.2 Finish Slopes.

Finish parking lot slopes should be not less than 2 percent in order to provide efficient drainage and prevent “bird baths” in low areas.

G1.4.2.1 **The slope of accessible parking spaces shall not exceed 2 percent (1:50) in any direction**, and should be as flat as possible while still providing reasonable drainage.

G1.4.3 Appearance and Layout.

Large visual expanses of paved areas should be avoided. Parking areas should be designed to incorporate islands with adequate radii at the ends of rows of parking, landscaping, curbs, drainage inlets, signs, restrooms and lighting. This will not only improve the appearance of a marina parking area, but will help meet typical regulatory agency permit requirements for various amenities.



G2. Restroom Facilities

G2.1 Restroom facilities at marinas and other recreational berthing facilities typically include toilet compartments, urinals, lavatories, mirrors, showers, interior/exterior lighting, drinking fountains, benches and walkways.



Marina Restroom Facility



G2.2 Restrooms may be provided for both men and women, or as local needs are identified, unisex toilet rooms may be provided in lieu of, or in combination with, conventional male/female restrooms.

G2.3 Restroom facilities must comply with all public health and safety requirements of local, state and federal agencies within whose jurisdictions such facilities are permitted, constructed, operated, maintained and managed.



Unisex Toilet Compartment Restroom



G2.4 The minimum number of toilet fixtures to be provided at a marina is generally one (1) toilet stool or urinal, and one (1) lavatory per sex for every 75 berths.

G2.5 Water closets provided in new construction, remodels, additions and replacements are to be ultra-low flush (ulf) fixtures with a maximum flow rate of 1.6 gallons per flush (gpf).



G2.6 Public restrooms in marinas should be designed, constructed and maintained to provide sanitary facilities that are clean, well lighted, safe and convenient for public use.



G2.7 Restroom buildings shall be barrier free.

G2.7.1 Where one or more toilet compartments are provided in a restroom building, including separate male and female facilities as well as unisex toilet rooms, **at least one of each type shall meet all applicable access requirements** for slopes; door openings; clear spaces; height, width and reach requirements; locks; water closets; urinals; water faucets; flush valves; partitions; toilet paper holders; grab bars; lavatories; mirrors; trash receptacles and signs.

G2.8 Restrooms in marinas should be located near the berths and parking areas, all of which must be linked together by accessible routes providing access to all marina features, services and primary functions.

G2.9 Access to and from restrooms should be provided so as to avoid to the maximum extent possible pedestrian traffic behind parked vehicles. This is of particular importance where small children are present. Also, a person in a wheelchair is not always readily visible in the rear view mirrors of parked vehicles including automobiles, trucks and recreational vehicles.

G3. Boat Launching Facilities

G3.1 Boat launching facilities typically consist of boat launching lanes, boarding floats, piles, vehicle-trailer maneuvering areas, roadways, parking areas, driveways, restrooms, walkways, landscaped areas and lighting.

G3.2 Boat launching facilities that are a component of a marina complex should be located so as to minimize conflicts in vehicle and boat traffic, as well as boater use patterns.



Boat Launching Facility Within Marina Basin



G3.3 Boat launching facilities should be designed and constructed in accordance with the Department of Boating and Waterways' technical publication titled Layout, Design and Construction Handbook for Small Craft Boat Launching Facilities. To obtain a copy, contact Boating and Waterways as indicated in the Introduction, page iv.

APPENDIX A SECTIONS B-G

C O M M E N T A R Y

Appendix A is provided to enhance and explain various aspects of the guidelines presented in Sections B through G. The capital letters and numbers at the head of each “**Commentary:**” are direct back-references to the material presented in the six sections of the guidelines. The intent is to keep the guidelines fairly brief, but to provide additional information that can be referred to if needed. The six guideline sections address the following topics:

- Section B Water Areas
- Section C Berthing
- Section D Guide Piles
- Section E Utilities
- Section F Shoreside Structures
- Section G Land Areas

The symbol in the right margin beside this paragraph appears at various places throughout the guideline Sections B through G. It is a flag indicating that commentary is provided in Appendix A on the particular subjects flagged. The commentary headings in Appendix A include the section back-references, thus providing a two-way reference system.



There are no commentary flags in Section A (definitions).

APPENDIX A

SECTION B - WATER AREAS COMMENTARY

B4.1.1 Minimum Water Depth Considerations

Commentary:

In coastal marinas the low water reference will usually be based on MLLW. If the extreme low tide periodically experienced at a given coastal site is -1.0 MLLW, this will probably be established as “design low water.” A 50 foot berth would need a minimum water depth of 8 ft, making the bottom elevation -9.0 MLLW. Additional depth may be necessary for silt retention between regularly scheduled dredging operations. Otherwise, silt buildup might encroach on the minimum berth water depth.

In establishing design low water for a coastal marina, it is probably not necessary or prudent to select the absolute lowest tide reading ever recorded at a given site, bay or regional area. Spikes in the records occur for both low and high tides, and should be disregarded if they are solitary events over a period of many years. For example, hourly tide readings have been recorded at a number of California coastal locations over periods of up to 50 years. Within that vast amount of data, there will be extreme data points at both the top and bottom of the tide range, extremes so infrequently experienced that they perhaps may need to be ignored in establishing design low water. For example, if a site experienced a single low tide event of -2.5 MLLW over a period of 20-30 years, that single low tide data point should not become the basis of determining gangway length and maximum slope. However, such low tide possibilities cannot be ignored from the standpoint of maintaining the integrity of the dock system, preventing gangways from dropping off the edge of a dock, etc. The dock may be out of normal service levels for a few hours during such an unusual infrequent event, including interruption of barrier-free access by persons with disabilities. Such extremely low tides will be predicted in tide tables well in advance, and notices can be posted to alert boaters of upcoming temporary conditions. With the volume of tide data available for the California coastline, establishing reasonable and safe design low water for a given marina should not be difficult.

Predicting low water levels in rivers, lakes and reservoirs is more difficult compared with highly predictable coastal tides. These inland waterways may be impacted by droughts that last for many years, resulting in low water storage, minimal water releases, and extremely low flows in rivers. If minimum berth water depths cannot be maintained during such low water periods, alternative actions become necessary such as moving the marina to deeper water or allowing it to ground out on the bottom until water levels rise. Two times during the 1970s and 1980s, California experienced droughts that lasted seven years. Marinas on Lake Shasta had to be moved several miles from their normal locations in order to keep them floating and

SECTION C - BERTHING COMMENTARY

C1.2.1.2 Minimum Main Walkway Width / Uniform Width

Commentary:

On main walkways over 300 feet long, the walkway width needs to be wider to address access to a larger number of berths, and handle the increased traffic load of people, supplies and equipment. However, the walkway width should not be arbitrarily reduced at the far end where the traffic is less. To do so is to introduce structural discontinuities, utility line complications, jogs in the walkway alignment, and irregularities in fairway widths and alignments. The total length of the main walkway and the size and number of berths served should determine the uniform width to be provided throughout the length of a main walkway. This will also address in a positive way the safety of the users. A long, uniform width main walkway will become familiar and predictable to the users, and will not cause confusion and problems at night or during storms when their attention is on other matters and concerns. Additionally, uniform width main walkways are more user friendly and accessible for persons with disabilities, paramedics, fire fighters and marina personnel.

C1.2.2 Main Walkways – Maximum Lengths

Commentary:

Considering a main walkway with 30 ft single berths along both sides, 700 ft will accommodate a total of about 84 powerboat berths, or 116 sailboat berths. A similar 800 ft main walkway will accommodate about 96 powerboat berths, or 124 sailboat berths. This amounts to a range of 42 to 62 single berths along each side of the main walkway, depending on the type, length and width of the berths and the width of the fingerfloats. At these maximum lengths, the “neighborhoods” become rather large, and the walking distances add up to over 0.3 mile round trip between the extreme ends of the main walkway. In consideration of carrying supplies, equipment and gear, additional walking distances stack up including the possible length of a marginal walkway, gangways, and the distances to restrooms, parking areas, harbor master’s office, restaurants, etc.

C1.3.1 Marginal Walkways – Minimum Widths

Commentary:

A dedicated gangway is one that provides access to a single main walkway. In such cases there is no need for a marginal walkway. A single gangway connected to a marginal walkway that provides access to two or more main walkways, is not a dedicated gangway.

It is probably impractical to increase walkway widths to odd dimensions such as 7.0 ft. On a wood dock structure, there would probably be a lot of waste as wood products typically are supplied in even number length dimensions. If the dock system is cast of concrete or fiberglass, or rotationally molded of polyethylene, attention should be given to the common mold sizes available through regional dock manufacturers. The point is to pay attention to the nominal sizes and lengths of commonly available building materials and make the best and most efficient use of those materials, eliminating waste wherever possible.

Marginal walkways typically have a minimum width of 8 feet based on the primary uses and traffic. The decision to reduce the width of a marginal walkway down to 6 feet should be tempered by anticipated pedestrian traffic patterns which can be influenced by gangway arrangements, location of restrooms and other marina destinations. Often marginal walkways are used for guest side-tie berths, or for special events such as boat shows and regattas. Once a marina is built and put into service, it is very difficult and expensive to widen marginal walkways in response to unanticipated uses and traffic. Such alterations can involve major changes to fingerfloat connections, utility lines, service boxes and guide piles.

.....
C1.3.2 Marginal Walkways – Maximum Length

Commentary:

Site conditions and the characteristics of a marina basin will generally dictate the maximum length of marginal walkways. Limited opportunity to provide additional gangways around a marina basin usually results in longer marginal walkways, and impacts parking, walkways, restrooms, lighting, barrier-free access and security.

.....
C2.1.3 Cross Slope on Accessible Route

Commentary:

When no smart level or surveying device is available to read a 2% slope, it can be approximated using a 12 inch bubble level and a small stack of 25¢ coins (quarters). Each coin is exactly 1/16 inch thick, making a stack of four 1/4 inch high. Placed on a level base, the 12 inch level supported on one end by four 25¢ coins will be at a slope of 1:48, slightly steeper than a 2% slope (1:50). Applied to an actual dock in the water, the quarters and 12 inch level can be used as a tool to estimate whether the cross slope is within 2%. Lay the level on the dock surface across the width. If it is not level, place quarters one at a time under the low end of the level until the bubble reads level. The number of quarters will indicate what the cross slope is. If it takes eight quarters (1/2 inch high) the slope is just over 4%; six quarters would be just over 3%, etc. This is a handy tool that can be very useful in the field.

.....
C2.2.1 Uniform Live Load

Commentary:

25#/ft² is not overly conservative with regard to low-use periods during the week or

season, nor is it too liberal to meet occasional circumstances that precipitate high pedestrian traffic during holiday weekends, or emergencies such as a marina or boat fire, oil spill, earthquake or flood event.

C2.2.1.1 Uniform Live Load - Application Problems

Commentary:

For example, in highly exposed locations where floating docks are periodically subjected to rough water, the use of thin-deck glue-laminated floating wood docks may be the only practical design choice. Such dock systems consist of a structural deck typically ranging from 3 to 6 inches in thickness to which flotation pontoons are fastened. Done properly, such a float system is flexible, has a low dead weight, and functions well in rough water compared to heavier dock systems.

However, in order to meet a 25#/ft² ULL, the attachment of the number and spacing of flotation pontoons necessary to comply with the loading and freeboard requirements effectively stiffens the thin wood deck and diminishes its ability to flex properly in rough water. The more pontoons, and the larger the dimensions of the pontoons, the stiffer the dock.

Illustration: A section of dock 8 ft x 50 ft has a deck area of 400 ft². A 25#/ft² ULL applied to the deck area results in a total ULL load of 10,000#. Assuming that the entire dock DL plus any applied live point load is about 4,000#, the total DL + ULL of the dock section is about 14,000#. One 12" x 12" x 12" cube (1 cubic ft) of totally submerged flotation material will support about 60#, or 5# per inch of submergence. Thus, 14,000# ÷ 60#/ft³ indicates the need for about 235 ft³ of flotation. The size and number of pontoons can now be determined with consideration to pontoon weight, depth and dimensions. Using deeper pontoons, with smaller length and width dimensions, will reduce the number and size of the pontoons, allowing for greater flexibility. Using shallower pontoons, with larger length and width dimensions, will require a greater number of larger pontoons and will stiffen the dock. These are the tradeoffs that the designer faces when using a thin deck flexible dock system.

In such situations, dock designers may be tempted to compromise the 25#/ft² ULL requirement in order to provide the desirable flexibility in a dock for a specific site. In past years, a ULL of 12#/ft² has sometimes been used to address this problem. However, **this is not a recommended option**. The 25#/ft² ULL has been established to address not only the performance of the dock system, but the needs and safety of the boaters who use the docks as well. During rough water periods, there may be little or no pedestrian traffic on the dock during a storm. When 3 to 4 foot high waves are rolling through such a dock system, it may be very difficult to even walk on the dock, depending of the frequency and height of the waves. However, under less severe conditions, the 25#/ft² ULL is necessary in the design of the docks in order to provide for public safety, protection of utilities and services built into the dock, necessary freeboard heights, and a reasonable factor of safety during periods of high pedestrian traffic as described above.

If a particular type of dock cannot be designed for a 25#/ft² ULL and function properly under expected site conditions, then it is not the type of dock that should be provided at that site. The solution may lie with operational procedures such as seasonal closures of a marina, or removal of docks from the water because of seasonal flooding, storms, ice, etc.

.....
C2.2.2 Snow and Ice Loads

Commentary:

Snow and ice zones are not limited solely to higher elevation lakes and reservoirs. The two-week period of sustained sub-freezing weather that occurred in Central California in 1990 did more damage to public and private property than the 1989 Loma Prieta earthquake. Insurance claims related to freezing damage exceeded those from the earthquake.



Heavy Snow Burden on Boats & Docks

If snow and ice are not removed from marina docks, a continued buildup can gradually increase the load and reduce the freeboard to unacceptable levels. Utilities may become submerged and structural connections may be stressed beyond design limits. Also, snow and ice on moored boats may impart heavy loads to the docks, and boat lines, intended to tie a boat to the dock, may pull a dock under water if the boat(s) is overburdened and begins to sink.

Marina decks should be designed, built and maintained such that snow and ice melt drains off the decks. Decks sometimes slightly curl, creating shallow basins that hold snow melt. Such ponded water may freeze overnight and create a “black ice” safety problem for both marina staff and boaters. Practical ways of addressing this problem include provision of drain holes in the deck, or using decking with openings such as 2x6s with ½ inch gaps between decking planks. Vinyl bumper material along the edge of a dock can also act as a shallow dam causing water to pond on the deck. Leaving ½” gaps between the ends of the vinyl strips will allow some of the snow melt to drain away. Care must be taken to insure that runoff does not drain into the flotation pontoons. This can sometimes be a problem on older docks with polyethylene pontoons fitted with plywood lids.



Serious Houseboat and Dock Snow Job

C2.2.3 Higher Uniform Live Loads

Commentary:

Examples of such applications include marina marginal walkways that are used by ferryboats, and scheduled events such as 4th of July marina fireworks celebrations that attract large numbers of people. Under such circumstances, marina personnel will often regulate the flow of people to avoid overloading of the dock system at critical locations. Hot spots need to be identified where people will likely gather and raise the live load.



Boat Show Pedestrian Traffic

C2.3.2 Unusually Heavy Live Point Loads

Commentary:

C2.3.2 Some persons with disabilities have a combined body and wheelchair weight of 800# to 900#, over twice the recommended design LPL. However, larger LPLs can be tolerated if they are infrequent, short term (a few minutes), and the dock layout will facilitate spreading temporary live loads. For example, a 12 ft wide marginal walkway has a greater capacity to receive and spread a temporary LPL than a narrow 3 or 4 ft wide fingerfloat. In addressing such temporary live loads, maximum cross slopes (1:50) on accessible routes must be maintained. Momentary reductions in the freeboard can be tolerated if cross slope requirements are maintained, and no electrical or plumbing components are jeopardized.

C2.4.1 Wind Loads

Commentary:

Depending on the direction of the wind, and where boats are tied in berths, a shadowing effect may occur. If a berthed boat is upwind of a dock, it is not necessary to apply the 15#/ft² WinL to both the vertical projection of the boat and the dock behind the boat. The vertical face of the dock over the length of the boat is in the “wind shadow” of the boat, and does not receive the full impact of the wind. However, good judgment comes into play here, inasmuch as the wind direction is not fixed, and can vary from perpendicular to parallel, relative to the boat and dock. When a berthed boat is on the downwind side of a dock, the boat would then be in the wind shadow of the dock, but only up to the height of the dock freeboard.

When applying a lateral WinL to a berthed boat(s), it is necessary to determine what is often referred to as the boat’s profile height. WinL is applied using estimated vertical areas of applied load measured in pounds per square feet. Since boats of various sizes and types do not have clearly defined profile heights, they have to be estimated, considering length of boat, gunnel height, cabin size and height, equipment, masts, rigging, antenna and other projections upon which the wind can

bear. For a given marina basin and geographical location, knowledge of the types of boats typically operated in the area and the wind characteristics are essential to good design. Generally, a realistic approximation of a boat's length and profile height can be made that will be accurate enough for application of WinL. In the case of a long dock with several side-tie berths, the profile heights of the berthed boats also must take into account the open areas between the bow and stern of each pair of boats. The final estimation will probably be some uniform height of X ft multiplied by the WinL, applied uniformly throughout the length of the dock.

.....
C2.4.4 Impact Loads

Commentary:

The designer must determine accurately the site specific factors involved in developing final design impact loads. Such site specific factors include specific marina conditions, marina layout, vessel characteristics and the type of marina dock system. The impact energy transferred from a large boat to a stiff, heavy concrete dock will be larger than that transferred to a more flexible, lighter weight wood dock. A "domino" effect brings into view the rigidity of the boat hull, how it responds to impacting a boat dock, the location, number and type of guide piles securing the dock, and the resisting effects of the dock pontoons below the water line. Such determinations are as much art as they are science, and require careful and prudent design.

.....
C2.5.1.2 River Based Marinas Near Low Bridges

Commentary Background Note:

Actual flood events jeopardized two low bridges in the Sacramento-San Joaquin Delta in central California in January 1997. **In one case**, a section of an upstream island levee failed, allowing the island to rapidly fill with water. The downstream end of the island had no outlet, and filled with water to a level higher than the river outside the levee. This resulted in a levee failure "into" the river which then carried trees, brush, large root balls, propane tanks and other debris into a small marina about 0.5 miles below the levee failure. Consequently, the marina failed and boats, docks, wood piles, levee debris and large masses of other materials washed up against a low bridge about 150 yards below the marina. **In the second case**, a river levee directly across from a marina collapsed into an island, resulting in an accelerated strong flow of water past the marina and into the flooding island behind the levee. The upstream marina piles began to sequentially snap under the growing flood load, and the collective mass of marina piles, docks, boats and debris was swept partially into the flooding island, and partially into a low bridge about 1 mile downstream.

In both of the above cases, levee failures were the original cause of the marina failures that ultimately placed the two bridges in jeopardy. Neither of these bridges failed, but the situations were serious enough to precipitate investigation, study and assessments of how best to address such situations in the future. Clearly, it is imperative that both sound marinas and sound levees be constructed and

maintained in river environments in order to avoid the events described above.

Commentary:

During a flood event, a levee failure may create a major diversion of water and cause a temporary reversal of flow direction in portions of a river, or network of rivers. Therefore, *marinas below bridges* during normal flow conditions may suddenly become *marinas above bridges* when temporary flow reversals occur.

If unusually serious environmental loadings can occur, a marina near a bridge must be totally adequate to withstand the flood level water flow as well as any debris load that may catch on the marina. If the marina fails, a low bridge near the marina may be in jeopardy of failure as well. Huge quantities of debris, including boats and docks, can be washed up against the bridge causing its closure or collapse. In flood events, such bridges may become escape routes for otherwise stranded people and livestock, as well as access to and from flooded areas for emergency and law enforcement personnel, vehicles and equipment. In such marina/bridge situations, the following suggestions should be considered in addressing environmental loadings in the design, construction and operation of a river marina.

(1) The integrity of the marina dock system must be maintained as the marina ages. Wood decays over time, and must be repaired or replaced. Steel rusts and must be re-coated, repaired or replaced as required. Piles have a known service life and must be evaluated periodically to determine if they will withstand the unusually severe applied loads that occur during a flood. And not only must all of the component parts of a marina be inspected and maintained, but the marina dock system as a whole must be maintained such that the various parts work together, and stay together during a crisis.

(2) Depending on soil conditions, the selection of marina piles in flood zones is critical. Marinas near bridges should be held in place with thick-wall steel piles, or pre-stress concrete piles, driven to depths that will allow for the full development of the bending strength of the piles during flood loading events. If a strong pile fails during a flood because of soft mud bottom conditions, the pile is totally worthless. However, if the piles stand during a flood event, a well designed, constructed and maintained marina will likely stand the test as well.

(3) The use of wood piles in river marinas near bridges is not recommended. Wood marina piles have some distinct advantages during normal water flow conditions. They are flexible, and will yield somewhat as river loadings occur, thus allowing other nearby piles to pick up and share the developing loads. They are quiet compared to steel and concrete piles when boats and other objects rub and clang against them. However, with age, wood piles gradually lose their structural strength, may become somewhat brittle, and can suddenly snap under load during a flood. If this happens at the upstream end of a river based marina, a single pile may become overloaded and snap, passing additional load along to the next pile. A zipper effect can occur as one pile snaps after the other, perhaps resulting in the partial or total failure of the entire

marina including piles, docks, boats, gangways, utilities and equipment.

In locations near bridges where it is likely that serious flood events will occur periodically, the marina designer and owner should consider installing a pile cable system that connects the tops of marina piles together in a containment network. The elevation of the cable must be higher than the elevation of the river levees in the area. The cable should be anchored to shore at both the upper and lower ends of the marina to provide a restraining force to the top of the piles to help them carry temporary high water loads. Such a cable system can also keep all of the piles and docks together on site if a failure occurs, thus preventing additional flood debris loading on a nearby bridge. However, such pile cable systems are not without potential problems. If the water gets too high, and the piles are not high enough, the cables themselves may collect and retain debris, causing additional loads on the piles and dock system. Also, the cables may constitute a hazard to marina personnel working on the docks when river levels rise to where docks are less than 7 feet below the cables. The permanent attachment of cables to the tops of marina piles is a concept that can be of great value in an emergency, but must be managed with care and awareness of the pros and cons.



Marina Pile-Cable Restraint System

An operational procedure should also be considered for river based marinas near bridges. A river level threshold can be established to act as a referee when river levels begin to rise to flood stage. For example, a river elevation of +20 feet, based on the local water level datum, might be a reasonable threshold that dictates preventive actions. Once the river hits + 20 feet, all boats should be removed from marinas in close proximity to river bridges. This will assist in keeping the various emergency loadings on a marina dock system within reasonable limits, and help insure that a failure does not occur to either the marina or the bridge. Boats removed from a marina under such an arrangement can be temporarily relocated to other nearby marinas not near bridges, or removed from the water and stored on land in pre-planned secure storage locations. The water level threshold and boat removal policy must be determined and agreed upon with the full cooperation and input from marina owners/operators, land owners, reclamation districts, and local, state and federal water agencies, as applies at a given site.

.....
C2.5.2 Wildlife Loading

Commentary:

The photo shows sea lions that have completely taken over a boarding float at a boat launching ramp in Monterey Harbor. The sea lions caused the boat ramp to be

shut down for several weeks in May and June, 2003, including portions of the parking area near the top of the ramp. They will also occupy marina docks and boats on moorings. Working with federal and state personnel, experiments that seemed to work included gently hosing off the docks near the sea lions, jingling car keys on a key chain, and spinning buoys on the docks in front of the animals.

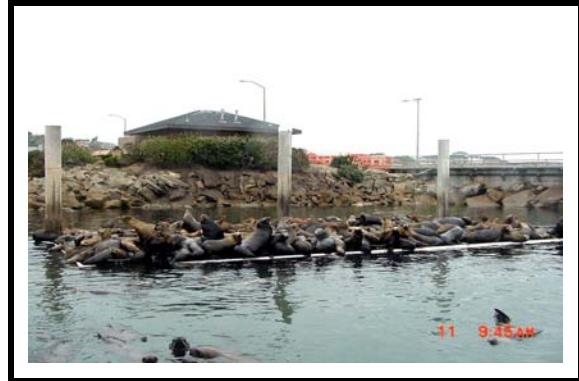

Sea Lions on Boarding Floats

It was also learned that the sea lions are highly intelligent and are able to accommodate new experiences (spinning buoys) once they realize that they will not be harmed or unduly inconvenienced. So, what worked this week may not work next week, or next year. It is an ongoing problem that must be addressed as a moving target. This can be a seasonal problem to some extent, and some years seem to be worse than others. The population of sea lions is declining worldwide, but is growing in the Monterey/Central California coastline areas.

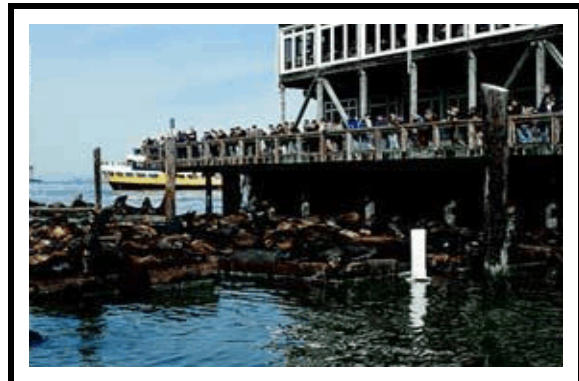

Sea Lions at Pier 39 Marina - San Francisco

The sea lions are notorious for fouling any area that they stay in for any length of time. They can occupy a dock or large boat(s) for days or weeks, and leave behind serious cleanup chores. Therefore, harbor staff must clean the boat ramp, docks, boat slips, etc. in preparation for allowing public use to resume when the sea lions migrate to other locations as their available food resources change.

C3.1 Minimum and Maximum Freeboard under DL only.

Commentary:

The minimum freeboard is to be sufficient to prevent walers, fender boards and utility lines from being in direct contact with the water surface under still-water conditions. It is advisable to provide a minimum 4 inch freeboard to the bottom of all walers and fender boards. This will extend the service life of these dock components that are so exposed to intermittent wet and dry conditions in the splash zone just above the waterline.

It is to be understood that these freeboard guidelines are general, and are intended to address typical recreational boat/berth needs and conditions found in California marinas. Where unique needs and conditions exist, freeboard specifications may

need to be altered accordingly. The users should always be kept in mind as well as the types and sizes of boats that will be berthed in a given marina. A freeboard of 24 inches is impracticable at a lake marina that primarily berths only low-profile aluminum fishing boats. 24 inches is too large a step down from the marina deck into such fishing boats, particularly for senior citizen boaters, but may be perfectly suited for large yachts and cruisers berthed in urban coastal marinas. The term “freeboard” addresses the vertical distance from the water surface to the marina deck. However, it also addresses the practical aspects of enabling boaters to be “**free**” to “**board**” their boats in consideration of boat type, size, and dock freeboard.

.....
C3.2 DL + ULL

Commentary:

Using the DL only minimum freeboard of 14" as a baseline, a dock designer has 4" of freeboard reduction within which to pick up the ULL applied throughout the dock system without going below a 10" freeboard. This can be addressed through selection of the flotation pontoon shape, wall thickness, weight, length, width, depth, number and distribution. A cubic foot of fresh water weighs about 62.5#, and a cubic foot of flotation pontoon weighs about 2.5 pounds. Therefore, each cubic foot of pontoon displacement will support about 60#. This provides a practical rule-of-thumb that every 1" of displacement of a 1 ft cube of pontoon flotation will support a load of about 5 pounds.

$$[62.5 \text{ \#/ft}^3 - 2.5 \text{ \#/ft}^3] \div 12 \text{ in/ft} = 5\# \text{ per inch of displacement of a 12"x12"x12" cube}$$

In coastal marina applications, use 64 #/ft³ for the weight of salt water.

A word of caution is in order here. In some dock designs, the pontoons are attached to the bottom of an open frame such as a steel truss. The decking is attached to the top side of the frame, and the utilities are run through the frame. The buoyancy capacity of the pontoons may be entirely adequate to carry 100% of the design dead and live loads and fully meet the freeboard requirements. However, if the pontoons are fully immersed under full design load, they have no reserve flotation capacity for emergencies. Additional loads can sink the pontoons all the way to the bottom but no additional pontoon buoyancy capacity will be realized.

In contrast, some other types of dock systems, such as those built on enclosed pontoons that extend well above the waterline, not only provide the necessary freeboard and fully meet the demands of dead and live loads, but also provide reserve buoyancy capacity should an emergency need arise.

Thus, there are tradeoffs between the various types of dock systems, and the conditions under which they will be expected to perform. Consideration of all of the above elements is essential to good design and construction of safe and long lasting marina docks.

C3.3 DL + LPL

Commentary:

Using the DL only minimum freeboard of 14 inches as a baseline, a dock designer has 4 inches of freeboard reduction within which to pick up the LPL which can be applied at any point on the deck not closer than 12 inches from any free edge, without going below a 10 inch freeboard. However, maximum cross-slope and minimum freeboard requirements must be met concurrently.

C4. Maximum Slopes

Commentary:

The difficulty of achieving and maintaining the maximum cross slope varies between marginal walkways, main walkways and fingerfloats, primarily because of the difference in widths. Marginal walkways must be at least 6 feet wide, but are usually 8 to 12 feet wide, are very stable, and usually do not present any problems with regard to cross slope listing under reasonable live loadings. Where gangways land on marginal walkways, additional flotation often is required to support the gangway DL, ULL and LPL, and well as maintain the cross slope and longitudinal slope requirements.

Main walkways must be at least 6 feet wide, are usually stable, but subject to slope problems related to storage box overloads on fingerfloats, and imbalances that can occur when fingerfloats are attached along only one side of a main walkway.

Appendix Table App-1 Fingerfloat Length to Width Ratios

Finger Width	Length Range	L/W Ratio	Finger Width	Length Range	L/W Ratio	Finger Width	Length Range	L/W Ratio
2.5 ft	16	6.4	4.0 ft	36	9.0	5.0 ft	62	12.4
	18	7.2		38	9.5		64	12.8
	20	8.0		40	10.0		66	13.2
3.0 ft	22	7.3		42	10.5		68	13.6
	24	8.0		44	11.0		70	14.0
	26	8.7		46	11.5		72	14.4
	28	9.3		48	12.0		74	14.8
	30	10.0		50	12.5		76	15.2
	32	10.7		52	13.0		78	15.6
	34	11.3		54	13.5		80	16.0
				56	14.0			
				58	14.5			
				60	15.0			

Fingerfloats are the more difficult problem since they are relatively narrow in

comparison to their length. As the length increases, the length to width ratio (L/W) increases as well, making it more difficult to maintain cross slope requirements. As seen in the table above, a 16 foot fingerfloat 2.5 feet wide is very stiff with a L/W ratio of 6.4. However, an 80 foot long fingerfloat 5.0 feet wide has a L/R of 16.0. Consequently, it may be necessary in certain cases to widen the fingerfloat widths to maintain cross slope stability. This decision will be influenced by the type of dock construction, the dead weight of the docks in comparison to the applied live loadings, and the types of boats expected to be berthed.

The cross slopes of walkways becomes critically important when they are part of an accessible route. Under no circumstances are the cross slopes along accessible routes to exceed 1:50 (2%). Since accessible fingerfloats are required to be at least 60 inches wide, this nicely addresses the cross slope problem. However, fingerfloats in the longer ranges may have to be widened to ensure compliance with the cross slope requirements, particularly with regard to the application of a LPL of 400# as addressed in C2.3.

It is one thing to comply with the required maximum cross and longitudinal slopes at the time of construction and acceptance of a new dock system. However, time, nature and use are hard on dock systems. Wood warps, checks and cracks, materials expand and contract, and fittings and connections loosen. Therefore, maintenance is critical in keeping marina docks within the required slope parameters. Not only will it keep a marina in good working order, but regular scheduled maintenance will also maintain an attractive appearance and keep the berths safe and convenient for boaters who use the facilities. Appropriate dock slopes must be provided and maintained during the service life of the docks.

C5.1 Material Considerations

Commentary:

Corrosion resistance is of particular concern in salt water applications. Steel and iron products must be coated or painted to avoid or control rusting. Because of its high strength characteristics, steel is commonly used in the manufacturing of piles, pile yokes, cleats, bolts, fasteners, brackets, utility cabinets and other marina components. Typical steel protection includes galvanizing, powder coating, painting, wrapping and encapsulating.

Another type of corrosion to be aware of is the destructive interaction between dissimilar metals known as galvanic corrosion. When dissimilar metals of different potentials are joined together by an electrolyte, such as rainwater or splash water from a marina basin, the more anodic metal will corrode. Connecting copper water pipe to a



SS Screw and Corroded
Cadmium-Coated Steel Washer

galvanized water tank, for example, will cause the galvanized tank to corrode very quickly. The use of stainless steel screws and bolts in direct connection with cadmium coated steel washers will corrode the washers. Also the direct contact between aluminum and steel in marina dock connections will also result in galvanic corrosion.

Solutions to galvanic corrosion problems include:

1. Avoid making connections between dissimilar metals.
2. If such connections cannot be avoided, refer to a “galvanic series of metals” and only join metals that are near to each other in the series, i.e. copper and brass.
3. Provide an inert insulator washer, sleeve or barrier between the two metals.

Other metals used in marinas include stainless steel, copper and aluminum.

Although they do not rust in salt water environments as does steel, they still need to be protected. Sea gull droppings are corrosive and can cause damage to pile rollers, pile caps and other non-ferrous metal components that are located directly below where sea gulls perch. Care must also be exercised to avoid conditions that lead to electrolysis which can destroy metal boat fittings, dock parts, steel piles, and the steel reinforcement in concrete sea walls and breakwaters.

Thermal expansion and contraction of materials is of critical interest in locations subject to extreme ranges of daily and seasonal temperatures. Steel is very elastic, and “grows” on hot days. When used on long railings on piers, for example, the sockets that connect the railings to posts, walls, etc., must be designed to allow the steel railings to slip and relieve the expansion and contraction stresses that occur. Alternative wood products used for marina decking, made of polyethylene and wood fibers, also expand and contract. The use of slotted bolt holes and washers, and appropriate gap spaces between the ends of decking boards, helps allow these composite materials to grow and shrink without buckling and the shearing of connectors.

Impact resistance is important for any marina component exposed to impact loads imparted by moving boats, equipment and/or people. Materials selected for pontoons, fenders, bumper strips, storage boxes, utility outlet cabinets, fire hose cabinets, etc., should be tough enough to do the job, but not brittle. They must have reasonable flexibility to resist impacts without breaking. A classic case is the bow of a boat striking the back of a utility storage box when entering the boat slip. In selecting decking material for docks, keep in mind the “heel loads” imparted to the deck by persons running on the docks during an emergency or special event. A 300 pound adult man running on a dock or gangway imparts a significant vertical impact load to the deck.

Weight of materials is important in addressing needed pontoon flotation capacities and required freeboard heights. Consideration must be given to the accumulated dead weight of bolts, nuts, washers, brackets, conduits, railings, gates, hinges, light standards, transformer housings and other metal components commonly used in

marinas. Every 5# requires another 1/12 cubic foot of pontoon capacity.

Strength of materials must be kept in mind when selecting steel, aluminum, wood, plastics, composites and other materials. Aluminum is corrosion resistant in most atmospheres, but may not be strong enough for hinge barrels on gates, gangways and storage boxes. Douglas Fir is difficult to pressure treat, but is much stronger than cedar or redwood, and can be used with longer span distances. Cedar and redwood are rot and decay resistant, but are relatively soft, are subject to faster wear on deck surfaces, and are not generally suitable for structural members on a dock. Objective consideration of the strength characteristics of the various materials being considered is necessary to good design and satisfactory service.

Past performance of materials is a great tutor and school master. If a material doesn't work in one setting, find out why before importing failure to another setting. Not all materials work well in all environments. Failures of materials often provide opportunities to make improvements in products and grow in the understanding of their applications. What works well in the cool moist environment of Crescent City may not work so well in the hot, intensive ultraviolet environment of the Mojave Desert. Attention to such factors should be applied to metals, plastics, wood and composite materials.

Minimum thickness of materials is often overlooked from the practical standpoint of durability and service life. For example, experience has proved that use of 1/4 inch diameter steel bolts in a dock system is usually not smart or cost effective in salt water environments. The cross section area of a 1/2 inch diameter bolt is about four times the cross section area of a 1/4 inch bolt. For the difference in cost and weight, it is prudent to use 1/2 inch or larger bolts for various connections. This is even more important if the bolts pass through pressure treated lumber, a corrosive environment for steel hardware components even if they are coated or galvanized. The same minimum thickness principle is in view with regard to galvanized steel knee brace brackets, pile yokes, utility hangers and brackets for supporting various equipment such as fire hose cabinets.

Flexibility of materials is often important to both performance and durability. A marina dock system is a dynamic structure constantly moving under the influence of winds, currents, waves, tides, boats and people. Materials must be selected that will not become brittle when cold, and still retain their shape and strength when unusually hot, i.e. during a fire or unusually hot summer afternoon. For example, water supply lines in a dock system must flex with the movement of the docks, yet remain intact while under pressure, including the fittings and connections. In rough water applications, a flexible wood dock system may provide superior performance and length of service as compared to a heavy, rigid concrete system.

Ultraviolet (UV) resistance is important to the service life of materials and appearance. Plastic products have been dramatically improved over the last 20-30 years with regard to UV damage resistance. UV blockers and other "miracles of modern chemistry" have extended the life of plastic products installed in full-sun

applications. Dock storage boxes installed in southern California marinas in the 1970s had a service life of only six to eight years because they became brittle and discolored, and had to be replaced. Electrical outlets and water supply hose bibbs were often installed on the face of the storage boxes, making replacement of the boxes difficult and expensive. Other examples of UV sensitive materials include building windows, utility towers, bumper materials, signs, recycled plastic decking, pile caps, and an array of cabinets for hoses, utilities and equipment.

Availability of materials should not be overlooked. New products become available, but may not be readily available in all regions and markets. Shipping costs may be unreasonably high for initial construction, and future lack of availability may make it difficult to obtain repair and/or replacement parts and materials. If interested in new materials and products, it is prudent to use them on a trial basis on relatively small projects to find out how they actually perform, and see if the manufacturer will follow through on guarantees and warranties. If not, the company probably will not be in business in the future to provide products and materials for repair, replacement or expansion. A track record of continued availability of product materials should be demonstrated by manufacturers and suppliers.

.....
C6.1 Pontoons

Commentary:

Water weighs from 62.4#/ft³ to about 64.1#/ft³ for fresh water and salt water respectively. Assuming that a cubic foot of pontoon weighs about 3#, including the pontoon hull and flotation foam, one cubic foot of totally submerged pontoon will support approximately 60 pounds of dead weight. Therefore, each inch of submergence of a 12"x12"x12" pontoon will result in a "rule of thumb" buoyant capacity of 5#. Thus, a 3'x5' rectangular vertical-wall pontoon has a 15 sq ft horizontal cross section area, and will provide a buoyant capacity of 75 pounds per inch of submergence. This rule-of-thumb figure makes it very easy to calculate the general requirements for pontoon flotation once the loadings are known on a particular marina dock system.

.....
C6.3 Pontoons and Structural Frames

Commentary:

The difference in stiffness of the dock frame and the pontoons can be a problem. Long, stiff, rigid pontoons do not work well when attached to a highly flexible glue-laminated wood dock system, particularly when the length of the pontoon is aligned parallel with the length of the dock. During periods of sustained high wave activity, the wood deck will flex in response to the wave height and period, but the connections with the pontoons will likely fail, ripping off or cracking the pontoon flanges, and causing progressive damage to the entire system. In such environments, use smaller, short length pontoons fastened with the pontoon length across the width of the dock. This will lessen the stiffening of the dock system along its length, and allow it to flex to a greater extent when necessary.

.....
C6.6 Pontoon Specifications

Commentary:

Some older pontoon shells that are still in service were made of roto-cast polyethylene. Made two at a time, they came out of the molds much like two bread pans connected at their rims. They were cut apart, resulting in two open-top rectangular hollow pontoon shells. Such shells were filled with pre-expanded foam snugly inserted into the shells, and capped with pressure treated plywood. 10 mill polyethylene sheeting was placed over the open-top foam-filled pontoon before the plywood cap was put on. This procedure helped stiffen the pontoon flanges, strengthened the connection to the dock frame, and helped ensure a watertight seal along the lip of the pontoon.

When this type of polyethylene pontoons are attached to the bottom of the frame, typically with galvanized lag screws and washers on 4 to 6 inch centers, a 2"x2" pressure treated wood backing strip should be used to insure that the pontoon flanges and covers are secured perfectly flat against the dock frame. This will guard against puckering of the pontoon flanges that tends to occur during warm weather as the result of thermal expansion. Such puckering forms small "mouths" between the lag screws that literally drink water in the splash zone around a pontoon and allow it to enter into the pontoon, filling existing air gaps, and progressively altering the buoyant characteristics. For example, where wind chop occurs primarily on the warm sunny side of an existing dock, pontoons will "sip" water on that side only, and the growing internal hydraulic pressure will gradually push the pontoon walls away from the foam cores. This can result in severe listing of the pontoons, a situation that is not usually self-righting.

Roto-cast polyethylene pontoons presently being used on marina docks are molded as self-contained units that are completely enclosed. The flotation foam has to be injected into the pontoons after the molding process is completed. Such pontoons are tough, reliable, and versatile for use on marina docks.

A suggested field method of addressing water filled polyethylene pontoons is to drill 1 inch diameter holes vertically up through the bottom of each pontoon shell about 2 inches diagonally from each corner. This will allow water both inside and outside the pontoons to equalize. The bottom of the pontoons will be several inches below the waterline, so no fuel, oil or other chemicals floating on the surface will be able to enter the pontoons and gradually "melt" the foam. This is an easy, effective, and inexpensive method to stabilize older "puckered" plastic pontoons as well as newer ones that may have taken on water. Since the primary function of the pontoon shell is to protect the foam core, drilling holes in the bottom, well below the water line, does not diminish the integrity of the shell or the foam. Do not drill drain holes through the sides of the pontoons.

The above commentary gives clear evidence as to why pontoons should not be partially filled with foam. If water gets inside a partially filled pontoon, the foam core may very well float to the top of the pontoon shell, allowing even more water to

enter the pontoon. This will diminish the effectiveness of the pontoon and cause further problems in maintaining freeboard and cross slope requirements.

.....
C6.7 Concrete Pontoon Reinforcement

Commentary:

Care must be taken to insure that reinforcing steel, wire fabric and other ferrous metal elements are not cast into the pontoons too near the surface of the top, bottom and sides such that rusting of the reinforcement will occur. If it does, iron oxide will begin to form on the surface of the steel, and continue to grow causing the concrete bond with the steel to fail. This will lead to the concrete spalling and being pushed away from the reinforcement, gradually destroying the effectiveness of the reinforcement. The use of additives to increase density and reduce porosity of the concrete can give added security against water intrusion and its effects on steel reinforcement, particularly in salt water applications.

.....
C7.1 Decking

Commentary:

Untreated softwood decking includes redwood and cedar. Heart grade redwood is resistant to rot, dry rot, and insect damage. However, it is low in strength, turns a dark color, can be used only over relatively short spans, is very expensive and hard to obtain. It is not recommended for marina decking use. In past decades, Port Orford cedar was used extensively for marina decking. It weathers to a silvery gray color with a feathery texture, and is not prone to splintering, splitting or checking. However, it too is expensive, difficult to obtain and has nearly vanished as a marina decking material.

Untreated Wood Decking

Species of untreated hardwood decking include a variety of tropical hardwoods such as Ipe and Brazilian Rosewood. They are very dense, heavy, and when applied properly will give a good long service life. However, these hardwoods are extremely expensive, greatly add to the dead load on a dock system, usually require stainless steel screw fasteners, and are impacted by the growing concerns over harvesting wood products in equatorial rain forests. Such decking is an option, but consideration of the above factors must be taken into account.

Pressure Treated Wood Decking

Softwood species such as Douglas Fir, Southern Yellow Pine, pine, and Hemfir can be pressure treated for use as marina decking. Recommended levels of chemical retention must be obtained during the pressure treatment process for decking applications in salt and fresh water splash zones. Pressure treated wood that comes directly in contact with the water has a higher retention requirement than wood used in the splash zone. The chemical treatment specification applies to “the zone of treatment” and varies with the dimensions of the lumber being treated. Refer to local pressure treatment associations for information and guidance in the use of pressure treated wood for marina use.

Pressure treated lumber is typically incised to enable the treatment chemicals to penetrate deeper into the wood cross section, thus providing better treatment. Incising is accomplished by running sawn and surfaced lumber through a roller assembly fitted with thin steel teeth that punch long thin holes into the surface of the lumber, typically on all four sides. When incised lumber is used for marina decking, it can become an unforgiving surface as it dries. At the points of incision, short stiff splinters often raise up and are unfriendly to shoes, bare feet, knees and hands. The treatment chemical is toxic and can cause various kinds of skin problems when the splinters penetrate the skin. Therefore, it is recommended that pressure treated marina decking not be incised. Since decking is less than 2 inches thick, this will not appreciably lessen the penetration and retention of the treatment chemical, but will enhance the usability of the product by boaters.

Recycled Plastic Lumber Decking

Recycled plastic lumber (RPL) is a product that is growing in use and popularity as a marina decking option. Manufactured from a variety of recycled polyethylene products, ranging from baby diapers and milk bottles to commercial grade manufacturing trimmings, RPL is available in a variety of dimensions, grades and colors. An extruded product, it can be made with various finishes, including grooves and serrations to improve foot traction when wet.

RPL is available in a pure form known as High Density Polyethylene (HDPE), as well as in a composite form combining wood fibers and sawdust with recycled polyethylene. Many generations of these products have been manufactured over the last 20 years, and some have been field tested by installing them in test sections in marinas. Initially the products were generally soft and pliable, and “grew” in length on hot days. A 2x6 decking board 16 ft long would grow up to 1 inch in length on a hot August day. Although that is a growth of only 0.52%, it caused buckling of deck boards and shearing of attachment screws. Additionally, the product would sag between supports on warm days, resulting in a poor appearance and unreliable surfaces for foot and cart traffic. The introduction of wood fibers into the decking solved some of the growth problems, but caused other problems such as delamination and deterioration. Over the years, new and improved recycled plastic lumber products have been developed that are stiffer, provide improved performance, and have a longer service life.

One of the drawbacks to RPL is its typical short span. Most RPL products have a manufacturer’s recommended maximum span within the range of 16 to 24 inches for 2" x 6" boards under a load of 80 psf. Marina decking is typically designed for loads of 20 to 40 psf. However, because of the basic characteristics of RPL, the recommended maximum spans should be complied with to provide the required support and avoid sagging.

The current industry standard for thermal expansion of RPL is 3/8" in 12 ft, a growth of 0.26%. Thus, product improvements have cut the typical growth rate in half over the last 15 to 20 years.

Many RPL product advertisements claim that such products will not stain and will last for decades without maintenance. The fact of the matter is that most of the wood fiber-poly decking will stain and must be maintained by regular removal of leaves, oil, and debris, and regularly scheduled washing and cleaning.

When selecting a RPL product for marina decking, a lighter color is probably best. It will be more prone to showing stains, but the lighter colors will not absorb as much heat as darker colors, and will be cooler and more user friendly to bare feet on hot sunny days. Darker colors will fade to some extent, but will probably be more resistant to UV damage.

Aluminum Decking

Extruded aluminum metal decking is a viable option to wood and plastic, depending on the application and location. Aluminum radiates heat exceptionally well and is typically a cooler decking material than wood or plastic decking products. It does not rust or rot, and is available in its natural color, or may be color coated with various products. It is light weight and does not appreciably add to the dead weight of the dock system. Various aluminum alloys are available, a critical element when selecting aluminum decking for salt water applications.

Aluminum decking typically is extruded with interlocking edges that improve the transfer of point loads not only longitudinally to the cross supports but to adjacent decking members as well. One disadvantage however, is that the continuous interlocking surface may not always drain well.

If aluminum decking is installed in its natural color, the decking should be lightly mineral blasted to eliminate the bright aluminum mill finish. Bright aluminum can be blinding on a sunny day and will not be well received by marina dock users or marina staff. Mineral blasting will also remove manufacturing stains and deposits of foreign materials, leaving a clean uniform slightly dull appearance.

Fiberglass Decking

Fiberglass decking is now available in channel-shaped cross sections. It is more resistant to UV damage than polyethylene plastic products, and is fairly easy to repair as necessary using fiberglass resins. Improved traction in wet situations can be accomplished by thoroughly cleaning the deck, liberally coating it with wet resin, and broadcasting it with small grain silicon sand, finely ground walnut shells, Carborundum, or other hard durable gritty substances. The resin will set and capture the grit, forming an improved traction surface. Finely ground walnut shells are porous and allow the wet resin to not only coat the walnut grains, but also to be absorbed into the walnut grains creating a high quality bond.

One drawback to fiberglass is that it can be damaged from impact loads and not immediately show visible evidence of such damage. Internal fibers may have been broken or otherwise damaged, and not be visible under casual observation. The application of another impact load at the same point may result in a "sudden" failure of a deck board which in fact is not sudden, but rather is progressive. Therefore,

fiberglass decking should be inspected at regular intervals and repaired as necessary.

Fiberglass decking can be manufactured by extruding it through an orifice concurrent with pulling strands of fiberglass through the orifice. Known as “pultruded” fiberglass products, they are exceptionally strong, and can be ganged together using small “T” bar or “I” bar elements to form composite decking panels 3 to 4 ft wide and up to 20+ ft in length. They are commonly used in chemical plants for their strength, reliability and resistance to corrosion. By virtue of their shape and characteristics, they drain very well, and can be coated with resin and grit as discussed above to improve traction as required. However, pultruded fiberglass decking is several times more expensive than more traditional types of decking, but may be the decking of choice for specific applications.

Concrete Decking

Concrete pontoons consist of relatively thin walls, bottom, and a thicker top that serves as the marina deck, cast around a core of marine grade expanded foam. Formed in steel forms that impart smooth finishes on the sides and bottom, the top is hand finished to provide an attractive, uniform, roughened texture that is easy to clean but provides good foot traction. The finish is typically a low to medium broom finish applied perpendicular to the direction of travel, with a steel trowel tooled edge 2 to 3 inches wide. This gives the pontoon a finished picture frame appearance, and avoids the jagged look of a broom finish that goes to the edges of the pontoon. Care must be taken to identify each pontoon as it is made with regard to its position and location in the marina layout in order to insure that the broom finish is imparted in the correct direction.

Concrete pontoons are typically manufactured in casting yards and shipped to the marina site on trucks or barges. Often stacked four high for transporting, the pontoons must be stickered in such a way that the pontoon on the bottom will not be cracked or otherwise damaged from the weight of the pontoons stacked above. Cracked pontoons should be rejected at the job site and returned to the casting yard.

The edges of the deck should be rolled over with an edge finish tool to avoid chipping during transport and assembly, and to provide a pleasing appearance. The pontoon casting forms should be fabricated to impart a chamfered edge to the vertical corners of the pontoon sides and the horizontal edges of the bottom, also to avoid chipping. This also facilitates removal of the pontoons from the forms.

Steel reinforcement placed in the pontoon forms must be carefully positioned and secured to insure maximum concrete cover when the pontoon is cast. Otherwise, when the wet concrete is introduced into the form, vibrated and finished, the foam tries to float to the surface of the concrete, moving the steel with it. This may result in the steel being too near the concrete surface, and rust will gradually occur, especially in salt water. Iron oxide will grow and eventually break the bond between the steel and the concrete and gradually ruin the pontoon. Diligent care to detail and

competent inspection during the manufacturing process can avoid costly and unnecessary premature repair and replacement costs.

Care in placement of the flotation foam inside the form is also of critical importance. If the foam shifts in the wet concrete during the casting operation, it may cause the walls, bottom and/or deck to be too thick or too thin. Also one side of the pontoon may be thicker and consequently heavier than the other side, causing the pontoon to list in the water to one side or the other. Some manufacturers actually weigh each pontoon after removal from the form and determine if the pontoon is balanced, or is heavy on one side. If the minimum thicknesses are achieved, slightly out of balance pontoons can be assembled into walkways and fingerfloats, turning them end for end as necessary to balance out the side to side weight differences. Such effort provides essentially level floats with little or no cross slope.

Concrete decking panels are sometimes used on wood frame and steel frame dock systems. They have the advantage of being removable for repair, replacement, or access to utility lines and pull boxes. Such panels must be seated flat in the dock framework, be small enough for handling during construction, but large enough to discourage or prevent removal by vandals. A utility chase down the center of a marina in the Bay Area was covered with 12"x1.5"x36" removable lightweight concrete covers which worked very well until vandals took great delight in removing them and throwing them into the Bay. It is recommended that removable concrete deck panels be cast with small square blackout holes toward the ends of each panel, through which small diameter steel rods pass. The blackout holes should be large enough to allow a special hook to be inserted and hooked around the steel rod for lifting the panels by marina personnel, but small enough to prevent the insertion of fingers for lifting and removal by vandals.

.....
C7.2.1 Gaps in Decking

Commentary:

Gaps wider than ½ inch are not permitted along an accessible route, and should be avoided everywhere else as well. Wider gaps cause problems for persons using crutches, canes and walkers, and can also cause problems for women wearing high heel shoes and small children walking or running barefoot. The shoe heels and small toes catch in wider gaps and can cause a person to trip and fall.



Utility Lines in Walkway Deck Gaps

There is a temptation to leave a wide gap between 2x6 decking at particular places on walkways to allow the placement of a water hose or electrical cord across a walkway. This may be an easy and inexpensive way to place utility lines across a walkway, but the extra wide gaps can cause problems for people using the docks.

.....
C7.3 Direction of Decking

Commentary:

Docks are always subject to some degree of torsional twisting. Dimensional lumber decking applied longitudinally will be subjected to torsional twisting, which will impart extra loads on the deck fasteners at the end corners of each decking plank. The planks will be torsionally twisted both clockwise and counter clockwise, which will gradually cause the corner screws or nails to loosen or break, allowing the opposing corners to lift up temporarily, or even permanently, creating a tripping hazard that is dangerous, hard to see, and is in the direct path of people moving on the dock. The application of the decking transversely essentially eliminates these problems. The shorter lengths of decking are perpendicular to the axis of the torsional twisting and the fasteners are subjected to significantly less stress. The corners of each piece of decking are also along the edge of the dock and are essentially out of the normal pedestrian path. The gaps between deck boards provide some degree of traction, and are compatible with the gap requirements on accessible routes.

.....
C8.3.1 Fore and Aft Moorings

Commentary:

Fore and aft moorings of this type only work well in clean waterways that are free of any kind of foreign greasy substances that can foul the pickup buoy and stern tie rodes. The handling of fouled buoys and rodes will result in soiled hands, clothes, gunnels and decks. Boaters do not like this, especially when they are unaware of the condition of the moorings, and suddenly have cleanup problems that are usually difficult and messy.

.....
C8.4.1.1 Increase of Scope

Commentary:

To illustrate, a heavy chain rode, even when being pulled laterally by a buoy, will hang nearly vertical below the buoy and gradually assume a catenary curve as the rode approaches the anchor. As the buoy is pulled horizontally away from the anchor by a moored boat, any slack will be taken up and a portion of the chain rode will be lifted off the bottom until equilibrium is achieved between the pull on the buoy, the weight of the chain rode and the holding power of the anchor. The weight of the chain rode will have a dampening effect on the forces involved, and will act as a type of shock absorber. In contrast to a heavy chain rode, a nylon rode will be much lighter, have less dampening effect, and require a much larger scope in order not to negatively effect the direction and magnitude of loads imparted to the anchor.

.....
C8.4.3 Anchors

Commentary:

Concrete Anchor Blocks

Concrete anchor blocks (not concrete cinder blocks) are relatively inexpensive and can be cast in a variety of sizes and shapes. Pyramid shaped blocks, with a low

center of gravity, work well on boat moorings, providing four sloped faces that cause the block to plow into the bottom when dragged horizontally by the mooring rode. Unless they are toppled over, the harder they are pulled, the deeper they dig in. With time, they will also “mud in” and bury themselves into the bottom to some extent, increasing their holding power. However, concrete anchor blocks are only about 60% effective as dead weight anchor blocks. Concrete weighs about 150 pounds per cubic foot out of water, but only about 90 pounds under water, thus reducing their effective dead weight as an anchor block. Concrete anchor blocks are also heavy to transport to a mooring site and require large cranes and equipment to handle and place them. They work better in a soft mud or sandy bottom as opposed to a rock bottom where sliding may occur.

Recycled Heavy Metal Anchors

Recycled heavy metal objects used for anchors include automobile and truck engine blocks, railroad trucks, and railroad tracks. For use in dead load anchors, steel is more efficient than concrete, weighing about 490 pounds per cubic foot out of water, and about 430 pounds under water. Each cubic foot of steel under water weighs about 340 pounds more than concrete, or about 4.8 times as much. Engine blocks work well as anchors, can be ganged together with chains or cables to make a larger anchor mass, but tend to roll around on the bottom more than a concrete pyramid. Railroad trucks are the sets of unitized steel axles and wheels that railroad cars roll on. They are typically available as surplus items, and can be used as they are, connecting the rode directly to the axle. Or, the axle can be cut in the middle to create two mushroom shaped anchors that are heavy and dig in when dragged. Surplus railroad track is also frequently available in sizes ranging from 60 to 90 pounds per yard. The rails can be cut in 4 to 6 foot lengths, cross stacked and welded in layers as required to create a specified weight maze that holds well in deep water situations.

Mushroom anchors are made commercially and are available in various sizes, weights and designs. They hold well in soft bottom conditions, but only hold in one direction. Thus, they should not be used on swing boat moorings.

Pile Anchors

Piles can be used as mooring anchors through the use of full length piles extending up above high water, or as stub-piles driven below the mud line.

Full length piles can be driven and fitted with mooring rings at various elevations on the pile to meet mooring needs at various water levels. However, this tends to corrode the hardware, is not always suitable to the boaters, and the rings and connecting hardware constitute somewhat of a protruding hazard to boats and boaters. Also, in applications where water levels change rapidly, a fixed pile mooring ring might be convenient and easy to use at low tide in the evening, but cause the bow of a moored boat to be pulled under water at high tide during the night. Conversely, a boat tied up at high tide could result in a situation where the boat is hanging from the mooring line at low tide, or the boater cannot reasonably reach the mooring ring at low tide. These kinds of situations can occur in tidal areas

as well as rivers and rapidly fluctuating water storage reservoirs. As seen below, the extreme tide ranges along the California coastline increase from south to north. At certain times of the year, a tide change of several feet can occur within a few hours.

<u>Location</u>	<u>Extreme Tide Range (ft)</u>
La Jolla	10.3
San Francisco	11.2
Alameda (San Francisco Bay)	12.0
Crescent City	13.8

An alternative is to provide a floating ring around the pile that rises and falls with the water level, and to which a boat mooring line can be attached. Foam-filled rubber tires have been successfully used in this way. They are tough, provide a good long service life, can be fitted with galvanized eye bolts and rings for mooring boats, and can be size selected for fitting over various types of piles of specific diameters. However, they may not be suitable in certain locations because of appearance and environmental permits may not allow their placement in a waterway.

Short stub-piles can be fitted with galvanized caps, heavy steel rings, lengths of heavy galvanized chain, and rode connectors. The top of the pile is driven a couple of feet below the bottom surface and the rode connected to the chain. Such piles need only be 6 to 10 feet long, depending on the bottom soil conditions. These stub-piles are buried below available oxygen in the water, and will last for many years. Such stub-piles can be made of recycled steel, plastic, wood or concrete piles, provided they are approved for such use in the required environmental and construction permits.

Steel Anchors

Steel anchors with flukes are commercially made and available in various sizes and designs. These anchors may be available as military surplus from the U.S. Navy or U. S. Coast Guard. Single anchors are commonly used to anchor vessels, but only hold in one direction, and cannot, therefore, be used on 360° swing boat moorings.

Spiral steel anchors can be used at locations with suitable bottom conditions. They are installed by divers who screw the anchors into the bottom and connect the mooring rodes. They are light weight relative to concrete and steel gravity anchors, easy to transport and handle, and have excellent 360° holding power for all types of mooring applications. They are commercially available from marine suppliers.

.....
 C8.4.4 Boat Rafting on Moorings

Commentary:

The rafting of boats on moorings and docks can become a serious problem if not addressed and managed by local authorities. During special events such as boat shows, or during seasonal celebrations such as spring break, floods of people can descend upon a facility or site and temporarily cause serious overloading.

Extreme Example #1: The original mooring system installed in 1973 in Ayala Cove on Angel Island in San Francisco Bay consisted of 39 fore and aft sets of moorings, each designed for one boat. However, over the next 10-15 years, as many as 400 boats sometimes rafted together on those 39 moorings, usually on a holiday weekend such as July 4th. You could literally walk across the cove stepping from boat to boat. Such gross overloading of the mooring system resulted in the dragging of the concrete anchor blocks, and a confusion of the previously organized layout of the moorings in rows by boat length sizes. The problem was eventually addressed by modifying the moorings, and the instigation and enforcement of mooring management by staff working at the cove.

Extreme Example #2: During spring break, thousands of college students typically flock to the stretch of the Colorado River known as Parker Strip to camp, picnic, swim and boat. Hundreds of boats raft together to form a floating bridge across the entire width of the flowing river. This can cause extremely dangerous conditions leading to destruction of equipment, injuries, drownings, and access difficulties for officers who are charged with boating law enforcement, rescue and first aid.



Boat Rafting at Copper Canyon, Colorado River

C8.5.1 Connections

Commentary:

A potential trouble spot is the mooring buoy. The mooring rode should pass up through the buoy and connect directly to the bottom of a mooring ring on the top of the buoy. Tension loading will then be transferred from the boat mooring line to the mooring ring on the top of the buoy, and then directly to the rode and down to the anchor. The buoy is neutral regarding transfer of load. The mooring ring must be loosely pinned to the top of the buoy to prevent inadvertent removal of the mooring ring from the buoy. A good and effective design utilizes a buoy manufactured with a galvanized steel pipe that provides a vertical conduit through the buoy. The rode can be passed up through the pipe and connected to the lower end of the mooring ring. The connection and rode can then be lowered back down into the pipe conduit and the mooring ring pinned to the top of the pipe. The connection is out of sight, is protected from the elements, and does not develop a bending moment. Many

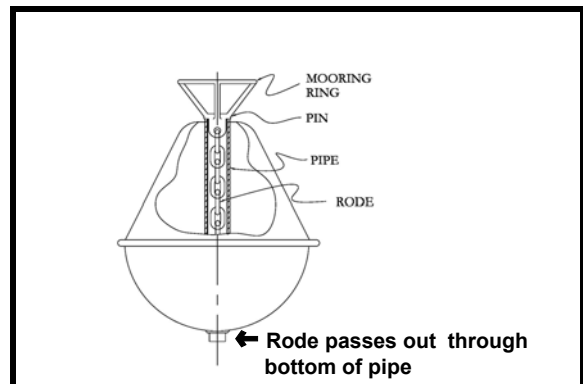

Mooring Buoy, Ring, Pin, Pipe and Rode

APPENDIX A

SECTION D - GUIDE PILES C O M M E N T A R Y

D2.2 Mooring Piles

Commentary:

The decision to provide mooring piles in double berths should be done after careful consideration of the local circumstances, the types of boats being berthed, and the needs, habits and opinions of the potential users. Some will utilize mooring piles to good advantage to secure their boats and will value them as increased protection against damage from other boats entering or leaving the other side of a double berth. Others will insist that the mooring piles are in the way and unnecessarily constrict the open width of a double berth.

A relatively inexpensive enhancement to a mooring pile is a floating mooring ring that rides up and down on the pile with changing water levels. Foam filled rubber vehicle tires of the proper diameter work well for this purpose. They are tough, long lasting, provide a means of securing a boat line (heavy eye-bolts & washers fastened through the tire sidewall), and may act as a bumper between the pile and the boat, depending on the type and size of the boat and the diameter of the pile and tire. Check with the local permitting authority to see if flotation-filled recycled vehicle tires are environmentally acceptable for this type of application.

D2.3 Cut-off Elevations

Commentary.

The pile cut-off elevation is a critically important design detail. Marina basins subject to surge, storm waves, sudden inflow of storm and/or flood waters, and water level build up from strong and sustained winds, can be subject to unusual temporary increases in water levels over and above normal seasonal and/or tidal high water levels. If these conditions are not considered and addressed, there is the risk that during unusually severe conditions, marina docks may actually float up and over the top of the guide piles, resulting in severe damage to or loss of the docks, the utilities, the boats, and perhaps even boaters who may be trying to secure and save their vessels. Do not under estimate the importance of sufficient guide pile height. Local conditions may require pile cut-off elevations of 6 to 8 feet above normal high water levels.

The critical importance of accurately addressing pile cut-off elevations cannot be overstated. Marinas with guide piles too short for local conditions have suffered damage and near catastrophe. The public marina at Redondo Beach rose precipitously high during a severe storm in the 1980s when waves overtopped the breakwater and nearly took the berthing system up and over the tops of the guide piles. The concrete piles were subsequently extended several feet. Portions of a

private marina in the San Francisco Bay Area actually came off the tops of the guide piles during a springtime situation when (1) high flows of snowmelt fresh water were entering San Pablo Bay through the Carquinez Strait, (2) an unusually high tide occurred, and (3) sustained strong off-shore winds “piled up the water” on the bay. That event also backed water up the Petaluma River and “floated” steel access covers off the storm sewers in Petaluma. High water levels in conjunction with strong sustained winds have also caused serious problems at marinas on the Salton Sea and other lakes that have no natural outlets.

.....
D3.1.1 Precast Concrete Piles

Commentary:

Precast concrete piles are not recommended for marina use. In comparison to the extended service life of most dock systems, the expected service life of a precast pile is too short. The cost to remove and replace a damaged pile is very expensive, interrupts marina operations, is highly inconvenient to berth renters, and is easily avoided by using prestressed piles during original construction. Under design loads, the concrete in prestressed piles will always be in compression because of the prestressed steel strands cast into the pile when manufactured. Concrete is strong in compression but relatively weak in tension. It would be an unusual event in a marina that would flex a prestressed concrete pile to the point of damage or failure.

Concrete piles are heavier than other pile types of the same nominal size. For example, a 12-inch diameter round concrete pile weighs about 118# per foot, while a 12-inch steel pile with a 3/8 inch wall thickness weighs 47# per foot, only about 40 percent of the weight of the concrete pile. Therefore, depending on site soil conditions, the weight of the pile may be an important design and material selection consideration.

.....
D3.1.2 Square Concrete Piles

Commentary:

If square concrete guide piles are specified, attention to the following details will provide better piles. Concrete piles are usually cast in long horizontal steel beds that provide a smooth form finish on three faces. The fourth face, which is exposed at the top of the form, is finished with a screed and float that often results in a rather rough finish. Such a finish is suitable for a building or bridge bearing pile, but that same rough finish on one face of a marina guide pile will grind away at pile rollers and rub pads, resulting in accelerated wear, maintenance and expense. Specifications must call for a smooth steel trowel finish on that fourth face, and the inspector at the



Rough Face on Square Concrete Pile

casting yard must be diligent to insure that the piles are finished as per the specifications. If jetting pipes and fittings are cast into the piles, care must be taken to clearly identify the top end of the piles so they are not accidentally driven upside down (true for circular and octagonal concrete piles as well).

Additionally, the pile specifications and the inspector should require that during driving operations the trowel finished face of each pile be turned away from main and marginal walkways for the least visibility to provide the best overall uniform pile appearance. All four edges of square concrete piles should be chamfered approximately 1 inch to diminish chipping of the edges and damage to boats and equipment that may come into contact with the piles.

D3.2 Steel Piles

Commentary:

Steel piles in salt water applications must be carefully designed with attention to proper steel alloys, coatings and protection systems to reduce pile corrosion. Steel piles are straight, uniform in diameter, relatively easy to drive, have predictable strengths, and can be field welded to meet varying length requirements as site conditions dictate.

In the past, marina designers usually avoided the use of spiral welded steel pipe in lateral loading applications such as marina guide piles. However, with contemporary computerized welding technology, there is no reason not to use spiral welded steel pipe piles in marinas, provided the specifications call for (1) complete penetration welds, and (2) smooth finished pile surfaces free of bumps and burrs that will accelerate pile roller wear and/or cause injury to persons who may come into contact with the piles.

When ultra high molecular weight (UHMW) polyethylene rollers are used with round piles, new rollers quickly wear until they “wear in” to the round pile shape as the rollers gradually assume full contact with the round pile. In doing so, the diameter at the middle of the roller becomes smaller, thus reducing the life of the roller. Additionally, the grinding movement of the pile relative to the pile yoke and rollers tends to work also on the corners of the rollers as they are subject to three degrees of continuous motion that is greatly amplified during severe weather and wind conditions. However, such wear factors are much less on a relatively smooth round steel pile than on a round concrete pile.



UHMW Rollers on Round Steel Guide Pile

Steel piles can be very noisy when docks, boats and rigging clang against them

during windy and stormy periods. Marina managers who operate facilities that have steel piles, liveboards and residential housing nearby, often receive noise complaints. Creative steps may have to be taken to dampen the noise as necessary.

Steel piles are usually coated or galvanized prior to driving, and care must be taken to protect these protective coatings when shipping, handling, driving, cutting and/or welding the piles. Pile caps are a necessity on steel piles to protect against the accidental or intentional deposition of trash, debris, oil, water, human waste, birds and animals into the top of an open pile.

D3.3.1 Pressure Treated Wood

Commentary:

Creosote treated piles cannot be used in California waters as per California Fish and Game regulations which prohibit use of oily substances.

Preservative retention rates in pressure treated wood piles must be in accordance with industry standards and recommendations for both salt and fresh water applications. Retention rates are to be specified in pounds per cubic foot in the zone of treatment, which is a ring of wood a few inches deep from the outside skin of the pile. Therefore, it is critically important that bolt holes and cuts not be made in the pile after treatment to avoid exposing the core of a wood pile. If the pile core is compromised by boring or cutting, marine organisms will gain entry and begin to consume the vertical core inside the zone of treatment. This gradually weakens the pile, and the structural strength will not be present when needed. Such compromised piles may appear to be sound, but can fail suddenly and leave the marina dock system in jeopardy.



Pressure Treated Wood Pile

If a pressure treated wood pile is bored, cut or otherwise damaged prior to driving, the integrity of the zone of treatment must be restored using industry recognized techniques.

Wood piles are not uniform in diameter throughout their length, but are generally tapered with the large end being the “butt” and the small end being the “tip”. They are commonly driven “tip first” for ease of driving and keeping the pile on location. It is similar to driving a tapered spike into a large timber. However, a guide pile is subject only to lateral loads, imparting a maximum bending moment in the pile just below the mud line. From a strength standpoint, it is usually better to drive wood guide piles “butt first” in order to locate the largest possible pile diameter at the point where the bending moment is greatest. Considered to be unconventional in the pile

E2.4 Utility Line Clearance Above Water

Commentary:

The object is to keep utility lines permanently out of the water to help insure a safe, reliable and durable service life. However, in cases where larger utility lines such as fire lines are required to cross other lines, and where connections and routing of lines get complicated, it may not be physically possible to meet the desired 6 inch clearance above the water surface. However, the goal should be to keep the utility lines above and out of the water to the maximum extent reasonably possible.

There may be applications where it is desirable to place water lines below the water surface to “insulate” them from freezing during the winter months. Such applications in California will probably be limited to relatively small marinas located on high altitude lakes and reservoirs in the mountains.

E2.5 Utility Lines Passing Through Structural Members

Commentary:

PVC pipe is frequently used for water lines and electrical conduit within the structural frame. Where it passes through framing members, the holes on each side of each member are to be chamfered $\frac{1}{4}$ to $\frac{1}{2}$ inch. A floating dock is a dynamic system that is constantly moving, and the utility lines within the structural frame will creep back and forth relative to the structural frame itself, thus causing a sawing action to occur that will eventually wear through a PVC water line or electrical conduit. By providing more forgiving edges and smooth points of contact, the life of the utility lines will be extended.

Another solution is the insertion of trumpet-shaped polyethylene plastic inserts into bored holes in structural members prior to insertion of the utility lines. This will provide smooth bearing surfaces, softened wearing edges and long utility service life if the utility lines and inserts are made of materials that have similar characteristics of hardness and wear resistance. If the inserts wear out or are damaged, new inserts of flexible material can be slit along one side, spread open, placed over the utility line, and tapped into the hole with the slit on the bottom side. As it is tapped into the hole, the slit should close up and the insert will lock into the structural member.

E3.5 Risers And Hose Bibbs Per Berth

Commentary:

To keep utility construction costs down, one riser and two hose bibbs are typically provided on a fingerfloat that serves two adjoining berths. Pedestrian traffic on such a fingerfloat is essentially limited to occupants of the two adjoining berths. It is recommended that water hoses be highly flexible in order to lay flat on the deck and be of a contrasting color for visibility.

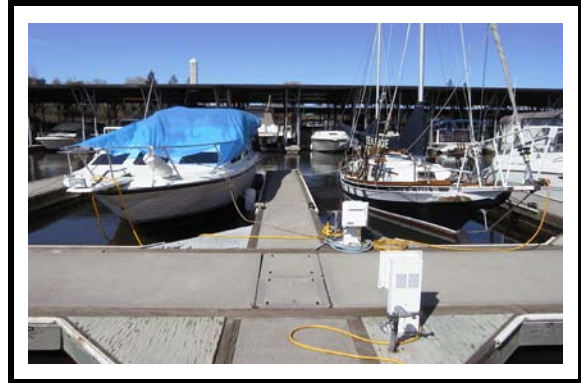

Utilities on One Side of Fingerfloats

E4.8 Fire Hose Cabinet Placement

Commentary:

A typical installation consists of the placement of fire hose cabinets at intervals of 75 to 100 feet along marina walkways. The interval between fire hose cabinets depends on the type and length of the dock being protected, as well as the length and diameter of the fire hose in the cabinets.

On side-tie docks, fire hose cabinets must be placed such that fire hoses can reach to all points along the length of the dock with appropriate extra hose length to address a fire on any part of a berthed boat.

On docks with fingerfloats, fire hose cabinets must be placed such that at least one fire hose will reach to the end of every fingerfloat, including enough extra length to manage the hose and address a fire on any part of a berthed boat.

Marina fire hose cabinets are available with fire hose racks for 1½ or 2½ inch diameter hoses in lengths from 75 to 125 feet. If we assume for a particular project that fire hose cabinets with 75 feet of hose will be used on a section of dock that has 30 ft fingerfloats, the cabinets could not be spaced more than 90 feet apart. The 75 ft hose could reach 45 feet in either direction and still have 30 feet in reserve to reach to the end of a fingerfloat. As the length of the fingerfloats increases, the intervals between fire hose cabinets decreases unless the length of hose is increased. A balance must be struck between the cost of installation, efficiency of use, and adequate fire protection for a marina.

Each fire hose cabinet should have a lockable access door, break-window for emergency access, a hand-operated valve, at least 75 feet of hose and a nozzle. Fire hose cabinets should be made of aluminum, fiberglass, polyethylene, Kevlar or other durable material that is colorfast and resistant to impacts and ultraviolet deterioration. They are typically red or yellow in color for high visibility and should be marked with reflective tape and materials that “wink” reflected light at night.

.....
E4.11.1 Charged Standpipes

Commentary.

There are some important aspects to charged standpipes that must be kept in mind:

- Standpipes are large in diameter, must be located below the deck, and must pass through, or just below, the structural elements of the dock system. This can cause serious design problems with regard to the structural design of the dock, and its performance and reliability during storms and emergencies.
- Standpipes are heavy and must be considered in the calculations for minimum walkway deadload freeboard. In situations where charged fire lines cannot be located along the centerline of a walkway, serious listing problems can occur, especially if there are fingerfloats on only one side of the walkway. In the case of side-tie docks where there are no fingerfloats to stabilize potential listing, it is critical that any charged fire lines be located down the centerline of the dock. Otherwise, the dock tends to roll, especially if the dock is 6 feet or less in width.
- Charged standpipes are subject to freezing in some locations, and may not be in operative condition should a winter fire occur.
- Standpipes charged to 200-300 psi are difficult to maintain. Under the dynamic movements of a floating dock system, these lines are highly prone to joint failures and leaks. They are distinctly different from similar charged water lines on shore in buildings that do not move. And when they do break or leak, repairs are difficult and expensive to accomplish.
- The presence of high pressure lines in close proximity to the public is not without potential safety problems. High pressure leaks are potential hazards, and sudden joint failures can be explosive in nature resulting in personal injury. This is a primary reason that standpipes must be located below the deck to guard against accidental damage, vandalism, and personal injury to the public and marina staff in the event of a sudden rupture.

.....
E4.11.2 Dry Standpipes

Commentary:

When considering installation of dry standpipes, the following should be considered:

- Dry standpipes are difficult to inspect for necessary service integrity without charging them and testing for sustained pressures and absence of serious leaks. If not properly maintained, a dry line may or may not be in serviceable condition when needed in an emergency.
- Even if a dry stand pipe is available, a local fire department may or may not use it. They may opt to connect to fire hydrants on shore and roll out their own

hoses to fight a marina fire.

E4.12 Drafting Fire Hydrants

Commentary:

Drafting fire hydrants should be a last resort option for the following reasons:

- Local fire departments need a reliable supply of clean water for fire suppression. Water drafted from a marina basin is considered to be contaminated with debris, salt and/or particulate matter that can potentially block and/or inhibit the flow of water through pumps, lines and nozzles.
- If potable water supply and fire suppression water are provided through a common supply line, the use of a drafting fire hydrant may contaminate the entire system unless protected by back flow prevention valves. Contamination will result in shutdown of all potable marina water supply until the entire system is purged, tested and restored to required public health standards.

E4.14 Strategically Located Calling Device

Commentary:

Acceptable devices include proprietary alarm systems, fire department alarm boxes, or non-coin operated public telephones. Such telephones will also serve as additional security in situations other than a marina fire.

E4.16 Foam Suppression Capability

Commentary:

Film forming foams (FFF) may be an appropriate option for fighting various types of marina fires. In the early 20th century, a developing foam technology produced some of the first air foams used to fight fires. By the 1970s, aqueous film forming foam (AFFF) was being produced for use in many fire fighting applications. Such foams are available in low, medium and high expansion formulations.

- Low expansion foam has an expansion rate up to 20:1, and is used for extinguishing liquid and solid material fires. Being a fairly heavy foam, it can be projected from safe fire fighting distances, and is very effective in creating an air-tight film over the fire, cutting off the oxygen supply.
- Medium expansion foam has expansion rates ranging from 35:1 up to 200:1, and is used on a variety of fires including plastics, rubber products (tires) and liquids. It is also useful to extinguish glowing fires as it produces a gas-tight covering over the fire. Mobile foam generators are capable of projecting medium expansion foam up to 100 feet.
- High expansion foam has high expansion rates up to 500:1, and is particularly useful in fighting fires in enclosed situations in buildings and semi-enclosed

structures. With its high expansion rate, light weight and low water content, it is highly effective in suppressing flammable gasses and in protecting property and objects from flame and heat damage. It has possible applications in covered berthing structures in which a volume of air space can quickly be “filled up” to starve out the fire, resulting in little or no water damage to boats compared to conventional sprinkler and water suppression systems.

E5.1 Electrical Codes

Commentary:

Marina electrical systems typically conform to the requirements of:

- Article E555 Title 24
California State Building Standards
- NEC Article 555 - Marinas and Boatyards, NFPA 70
National Electrical Code (NEC)
National Fire Prevention Association (NFPA)
- NFPA 303 - Fire Protection Standard for Marinas and Boatyards
- Local city, county and district codes as applicable

The NFPA codes have been developed and maintained by the National Fire Protection Association, a private association that serves local, state and federal entities. The intent of the codes the association sponsors is clearly conveyed in the last paragraph on page one of the 2002 Edition of NFPA 70, which reads as follows:

“This Code is purely advisory as far as the NFPA and ANSI are concerned, but is offered for use in law and for regulatory purposes in the interest of life and property protection.”

Therefore, local government agencies typically adopt NFPA codes for application in their respective jurisdictions. However, there may be instances where local codes are more restrictive in some regards to address special conditions. In such cases, the more conservative code requirements should be complied with at a given site.

E5.5 Electrical Outlets at Berths

Commentary:

During the 1970s, 80s and 90s, marina electrical guidelines generally recommended one (1) 120 volt 30 amp electrical outlet for all berths under 50 feet, and two (2) 120 volt 50 amp electrical outlets for all berths 50 feet and over. However, with the growing cost and demand for electrical power throughout California, it is now prudent to emphasize the recommended minimum level of electrical service, and encourage marina electrical designers to determine the actual power needs for the types and sizes of boats to be berthed in a marina. The

costs of more electrical power are not limited to just the power consumed by the boaters. It also includes larger wire sizes, greater equipment capacity, more transformers, larger wire/cable chase ways in the dock systems and increased installation and maintenance costs.

In some larger marinas that provide berths for larger boats, much higher levels of electrical power are being provided. Large yacht manufacturers have indicated the need for shore power at the following levels:

50-70 foot berths	two 50 amp outlets
70-80 foot berths	one 50 amp outlet, and one 100 amp outlet
80+ foot berths	two 100 amp outlets

These larger berths and their reasonable levels of electrical power demand are beyond the scope of these guidelines. In such cases, check with local building officials, power companies and recognized marina electrical experts who can advise and assist in the determination of actual needed service levels. Keep in mind that such elevated levels of electrical power service greatly increase the construction cost of each such berth as well as the consumption of power. Such berths should be sub-metered to identify the actual power consumption and cost.

In determining the projected electrical power demand for a marina, conservation of electrical power must be balanced with the actual power demands of boats that will occupy a marina. Larger boats are now being fitted with electrical equipment and features far beyond what is typically found in a residential home, including:

120 volt GFCI protected outlets	lighting, internal and external
televisions (each compartment)	telephones
stereo systems	ice makers and chippers
DVD players	refrigerators
digital satellite receivers	freezers
hydro-jet bath tubs	water heaters
ventilation systems	saunas and hot tubs
telephones	stoves, ovens and ranges
microwave / convection ovens	coffee makers
food processors	trash compactors
pressurized water systems	heating systems
washers and dryers	air conditioners
pumps (for fuel, water, sewage, etc.)	vacuum systems (for cleaning)
communication systems	transformers
air compressors	dehumidifiers
automatic shutters, doors, hatches, etc.	movie theaters

Marina electrical issues should be specifically addressed during the preliminary design phase of a marina project, and a competent marina electrical designer should be a member of the design team. In designing the electrical system,

consideration must be given to the pro and con effects of the proposed marina layout, length of feeder lines, voltage drops, number of outlets per circuit, and the estimated power requirements of the types and sizes of boats that will occupy the marina. This is essential for both new and altered marina projects.

E5.7 GFCIs Not Recommended For Berth Outlets

Commentary:

Laboratory tests by various agencies and industries over the years have shown that 5 milliamps (0.005 amp) is a safe and appropriate threshold for use in designing GFCIs to protect people. In a potentially wet environment around boats and boat docks, currents over 5 milliamps can cause injury or death to a person who is adequately grounded. Even small currents can cause a person's heart to stop, resulting in death from electrocution or electrical shock drowning if they are in the water. Therefore, GFCIs with tripping levels higher than 5 milliamps **must not** be used in a marina with the thought of protecting people.

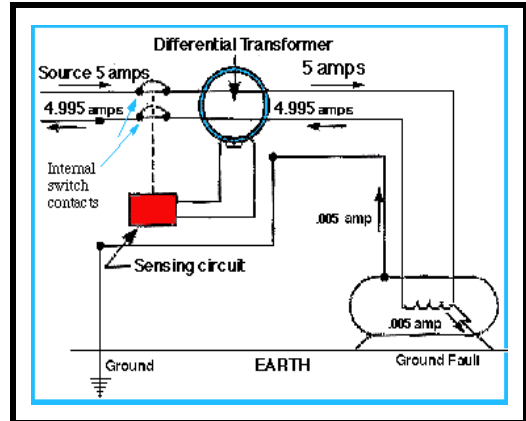

However, the installation and maintenance of 5 milliamper GFCIs often results in nuisance tripping, a common problem that usually leads to frustration for boaters, maintenance staff and marina management. It can be caused by moisture problems in the devices themselves, “dirty boats” with sub-standard electrical systems, and electrolysis problems.

The primary goal of a marina owner/operator is to make a profit. However, satisfied berth renters is an important element in achieving that goal, and the installation of GFCIs that do not provide the results hoped for can lead to serious problems between marina staff and clients that are difficult to overcome. The resolution of such problems is usually expensive for both sides and can take lots of time to resolve to mutual satisfaction.

The presence of GFCIs in a marina can actually result in a false sense of security for not only the boat owners but for marina maintenance staff as well. There are far more maintenance workers who are harmed by marina electrical systems than boaters. The knowledge that a GFCI exists in a marina electrical outlet typically carries with it the assumption that it is working properly and will guard against both harm to persons and damage to equipment. A false sense of security can be dangerous for all concerned.

The installation of GFCIs carries with it the imperative necessity to test, calibrate, maintain, repair, and/or replace the devices on a regular basis. Such demands on a marina budget can become a low priority and the performance of these important

safety practices gets delayed or omitted in lieu of other pressing matters. However, if GFCIs are used, marina management must commit to:

- planning, managing and supervising a program of regular and systematic testing of the devices;
- training staff to use approved testing equipment and procedures;
- procuring and using appropriate testing equipment that will actually create a ground fault to determine if the device is working properly, and trip at the design ground fault amperage of not more than 5.0 milliamp;
- using, maintaining and updating correct procedures;
- maintaining accurate inspection and maintenance records; and
- informing, encouraging and requiring boat owners to inspect, correct and maintain the electrical systems on their boats.

E5.9 Sub-Metering of Marinas

Commentary:

The installation and use of kilowatt hour sub-meters in marinas has a dramatic impact on electrical power consumption. A documented field study funded by DBW, executed by ADCO Electric, Inc. of Santa Cruz, CA, and published in 1995, shows that sub-meters will reduce actual power consumption by nearly 50 percent. The field study is titled Report on Documented Field Study of Actual Electrical Power Use in California Small Craft Harbors, dated May 1995.

Utilization of sub-meters in a marina has a significant effect on high peak use as well. The field study revealed that the highest recorded peak amps, which reflect worst condition use, were also reduced by nearly 50% when sub-meters were in operation.

Another benefit of sub-metering is a significant conservation of energy, along with a reduction in monthly operation costs. It is typical for an existing non-sub-metered marina to realize a 60-70 percent reduction in annual electrical utility costs after sub-meters are installed.

Example: The public marina in Antioch, California installed sub-meters in the 1990s, and quickly realized a 66 percent reduction in power consumption. The marina's electrical bill dropped from \$36,000 per month to approximately \$20,000, of which \$14,000 is recoverable from the boaters under CPUC rules for sub-metering marina boat slips.

Prior to installation of the sub-meters, the cost of electrical power was included in the monthly berthing fees. If such monthly berthing fees are based solely on the length of the berth, inequities occur. For example, it is well known that larger boats use disproportionately more electrical power than smaller boats as they typically have more and bigger equipment. But does a **typical 60 foot boat** use twice as much power as a **typical 30 foot boat**? Obviously, there are variables involved here. But what does not vary is the length of berths and the marina

basin water surface areas required for berths of various lengths. A single berth for a 30 foot power boat requires a total area of 960 square feet, including the water area in the berth, the fairway in front of the berth, and the main walkway and fingerfloat deck areas that define the berth. However, a single berth for a 60 foot powerboat requires a total area of 2,628 square feet, more than 2.7 times the required area of the 30 foot berth (see Table B-7). The utilization of sub-meters removes the cost of electrical power from the inequitable berth length/area equation, identifies actual power consumption, allocates costs to the actual users, and encourages significant savings of electrical power and money for both marina operators and their customers.

Sub-metering will also result in a decrease in fire hazards by encouraging boaters to unplug or turn off unattended/unnecessary heaters, lights, air conditioners, refrigerators, freezers, trash compactors, battery chargers, radios, TVs, computers, and other power equipment and devices.

Another positive impact of sub-metering is the potential increase of the effective capacity of older electrical systems on existing marinas. Aging marinas experience the growing demand for more power as more electrically demanding boats occupy the berths. Marinas that allow liveaboards and overnight/weekend occupation of berthed boats experience increased power demands. This results in a growing frequency of circuit breaker tripping, maintenance, repair and/or replacement. The installation of sub-meters has an immediate impact on the boater's perspective on the cost of power and its impact on their wallets. Typically, wasteful use of power is greatly reduced, making capacity available to meet legitimate increases in demand and extending the useful life of existing electrical systems.

In California, prior to 1993, only private marinas could install and operate sub-meters. However, Assembly Bill 2108, signed into law on October 11, 1993, specifically allowed public marinas to sub-meter as well. Along with this legal approval came the requirement to comply with rules and regulations dictated by the California Public Utilities Commission (CPUC). Strict adherence to the rules is mandatory, requiring marina operators to collect monthly fees, independent of the monthly berthing fees, to offset the costs of installing, maintaining, replacing, reading and billing related to the sub-meters and other related electrical equipment. The monthly fees are based on single-phase service, polyphase service, and energy charges per kWh during summer and winter periods. Check with your local electrical utility provider to obtain a copy of their rate schedule.

Authorization to sub-meter a marina is conveyed through a document known as Rule 18. All electrical power utility companies in California have a Rule 18, or variation thereof. As an example, the following excerpt is taken from the Pacific Gas and Electric Company Rule 18, page 3:

“C. FURNISHING AND METERING OF ELECTRICITY

3. MARINAS AND SMALL CRAFT HARBORS

Notwithstanding any other provision of this rule, PG&E will furnish electrical

service to the master-meter customer at a privately or publicly owned marina or small craft harbor. The master-meter customer may sub-meter individual slips or berths at the marina or harbor but may not sub-meter any land-based facility or tenant.

If the master-meter customer sub-meters and furnishes electricity to individual slips or berths, the rates and charges to the user must not exceed those that would apply if the user were purchasing such electricity directly from PG&E.”

To illustrate the actual benefits of utilizing marina electrical sub-meters, the field study included a marina that had two separate berthing areas: one sub-metered, the other not metered; one with recreational boats only, the other with commercial fishing boats only. Over a period of one year, the two berthing areas had nearly 100% occupancy, and were monitored using separate utility company meters. Over the study period, ***the unmetered 144 recreational boat berths used 246% more electrical power than the sub-metered 228 commercial fishing boat berths.*** Even considering that there may be different patterns of electrical power consumption between recreational boats and commercial fishing boats, the fact that 37 % fewer recreational boats used 246 % more power than 228 commercial fishing boats is still a very significant indication of the impact and positive benefits of sub-meters in a marina.

If sub-meters are installed in a marina, they must meet the requirements of CCR Title 4, Division 9, Chapter 1, Article 2.2. Two of the more important requirements address the location and height ranges of the sub-meters with regard to personnel who read, calibrate, maintain, repair and replace sub-meters. For details, see the above cited code or contact staff at the Division of Measurement Standards, California Department of Food and Agriculture.

.....
E5.11 Electrical Power Centers (boxes, pedestals and towers)

Commentary:

Individual power centers are usually low in profile, 12" to 16" high, have two electrical outlets, two breakers, one low voltage (7-watt) fluorescent deck/outlet light with a photo-electric cell, fuses if required, and perhaps telephone and cable TV jacks. The power centers can be mounted on posts or power pedestals to raise the outlets to more convenient heights for boater use and staff maintenance. They are often mounted in the front face of a dock storage box used to store supplies, materials and equipment for operating and maintaining a boat.



Power Center and Separate Water Supply

When potable water lines and hose bibbs are also provided in the face or sides of dock storage boxes, safety problems can develop if a water line leaks or breaks, creating a wet environment. It is not recommended that electrical power outlets and water supply lines and hose bibbs be installed in the same storage box. The boxes are tall enough to easily be struck by the bow of a boat entering the boat slip. Such an impact can punch holes in the back of the box, rip it free of its attachments to the decking, and/or break the water line within the box or below the deck. It is advisable to keep the water service completely independent of and separated from the electrical service for safety, and ease of repair and maintenance.



Storage Box with Power & Water Supply

Electrical power pedestals are usually taller than storage boxes, and can be up to 60 inches high, have greater utility capacity, and can provide a full service package including electrical power, telephone, cable TV, low-voltage lights, potable water lines and hose bibbs. Care should be taken to locate such pedestals so as to avoid the storage box utility problems described in the paragraph above. Power pedestals can usually house up to four electrical outlets, breakers for each outlet, two TV jacks, two telephone jacks, two hose bibbs, larger low-voltage fluorescent lights, and two kilowatt hour electrical submeters. Power pedestals should probably be used on all accessible boat slips because of height and reach-range requirements that apply to all dock features and components except cleats and other boat securement devices.



Full Service Utility Tower

An operational problem may occur if boaters “lasso” and tie up their boats to tall power pedestals. This can impart lateral boat line loads that the pedestals are not designed to carry. When waves are generated within a marina basin, whether from wind or boat traffic, a line secured high up on a pedestal can cause a large bending moment in the pedestal resulting in damage to the utility systems, pedestal, anchor bolts, and decking under the pedestal. Here again the location of power pedestals and their orientation to the berths is important to safe and convenient operation and trouble-free service.

APPENDIX A

SECTION F - SHORESIDE STRUCTURES C O M M E N T A R Y

F1.1 Piers

Commentary:

There may be instances where piers are multi-use and a higher ULL would be necessary. Where trucks, maintenance vehicles, rescue vehicles and other heavy loads will be on a pier, a ULL of 100#/ft² may be required.

F2.1 Minimum Number of Gangways

Commentary:

The minimum number of gangways for a specific marina is a complex matter that is influenced by the number of berths, the inventory of berth sizes, the shape and size of the marina basin, the characteristics of the marina basin shoreline, the location of shoreside facilities, and the requirements of the local fire chief and regulatory permitting agencies.

From a fire safety perspective, it is always desirable to have a minimum of two emergency avenues of exit, i.e. two gangways serving each separate section of berthing in a marina. However, it is often impractical, economically infeasible, and environmentally undesirable to do so. Additional gangways will often reduce the number of berths in order to provide space for another gangway, will double the cost of providing and maintaining the gangways, and will cause problems in obtaining environmental permits. In California coastal waters, permitting agencies such as the Bay Conservation and Development Commission (BCDC) consider a gangway over water to be "bay fill" that diminishes the water surface area which in turn is considered to be a negative impact. Therefore, the decision as to the minimum number of gangways in a specific marina is subject to the parameters of the particular site and the collective wisdom and influence of the parties involved.

F2.3 Loadings Transferred from Gangways to Docks

Commentary:

The live load (LL) transferred from a gangway to a floating dock may be calculated on the basis of 20#/ft² applied to the total surface area of the gangway deck, the same ULL applied to low traffic area floating docks. This will result in the LL being transferred from the gangway to the dock as a moving point load via an axle and two wheels on the lower end of the gangway, including both gangway DL and ULL. The two gangway wheels roll back and forth on the surface of the dock as water levels rise and fall. If a gangway serves a high traffic dock area with a higher required ULL, that ULL should be used to calculate the LL transferred from the gangway to the floating dock.

The more critical situation typically occurs during low water periods (i.e. low tide) when the relative position of the lower end of a gangway is closer to the edge of a floating dock. If it is necessary to have a gangway “land” near the edge of a floating dock, supplementary flotation may be necessary under the edge of the dock below where the gangway rests. This extra flotation might be necessary to maintain safe and required freeboard levels and cross slopes under various loading conditions.

Full LL on a gangway probably will not occur very often. Therefore, to transfer the full gangway structural design ULL of 50#/ft² to the gangway-supporting docks would result in “unloaded” docks that ride unnecessarily high in the water for long periods of time, causing excess dock freeboard. This causes localized differences in freeboard and problems with cross-slopes, especially along those areas that are part of an accessible route.

The above reduction provides a reasonable consideration of both typical and extreme conditions without compromising safety. In the event that a gangway was loaded with the full design ULL of 50#/ft², this short-term load would spread within the dock system. Freeboard would diminish, pontoons would be forced deeper into the water, and the dock’s structural frame would cause the load to spread to other nearby pontoons that would pick up portions of the gangway load. Any well-designed and constructed dock system should be capable of supporting additional short-term loads that temporarily reduce the design freeboard. Once the higher than normal loads are removed, the dock recovers and freeboard returns to normal levels. This dynamic action described above can only be tolerated if the minimum freeboard requirements for floating docks are still complied with.

.....
F2.5 Minimum Clear Width of Gangways

Commentary:

Nominal widths of gangways typically vary from 36 to 60 inches, depending on location, expected traffic loads, gangway lengths and special needs.

If gangways are too narrow, they can be awkward to use, and people moving up and down a gangway at the same time cannot pass safely and comfortably, particularly during low water periods when gangway slopes are greatest. Conversely, if gangways are too wide, the handrails on each side cannot be used at the same time if desired and needed. This is important to people with small children, senior citizens, persons with disabilities, etc.

Considering the requirements for 1¼ to 1½ inch handrail diameters, 1½ inch clearance between the handrail and the gangway railing posts or other supporting elements, the 36 inch minimum clear width, and the width of the railing structure, the total overall minimum width of an accessible gangway will be about 48 inches.

F2.6.2.2 Maximum Gangway Handrail Height

Commentary:

It is recommended that gangway handrail heights not exceed 35¼ inches on gangways that exceed a maximum slope of 3:1, measured perpendicular from a gangway deck surface to the top of the handrails. As a gangway (and the attached handrails) rotates vertically with changing water levels, the perpendicular height of the handrails remains constant. However, as seen in the table below, the vertical height from any point on the top of the handrail to the gangway deck progressively increases as the gangway slope increases. At zero slope, a 35¼ inch handrail height is both perpendicular to the deck and vertical. But at a slope of 3:1 the vertical dimension increases from 35.25 to 37.2 inches, and at 2½:1 it increases to 38.0 inches. So at maximum allowable slopes, the vertical dimension is still at or below the 38 inch maximum allowable height.

If, however, the top of the handrail is 38 inches high measured perpendicular to the gangway deck, the vertical dimension increases to 40.1 inches at a 3:1 slope, and 40.9 inches at a 2½:1 slope, both well above the 38 inch maximum allowable. Therefore, it is recommended that handrails not exceed a maximum height of 35.25 inches on gangways that exceed a 3:1 slope.

Table App-2 Gangway Handrail Heights

Slope ▼	Perpendicular Height to Top of Handrail from Gangway Deck (inches)									
	34	34.5	35	35.25	35.5	36	36.5	37	37.5	38
	Vertical Height to Top of Handrail from Gangway Deck									
3:1	35.8	36.4	36.9	37.2	37.4	37.9	38.5	39	39.5	40.1
2½ :1	36.6	37.2	37.7	38	38.2	38.8	39.3	39.9	40.4	40.9

F2.7 Gangway Non-Skid Deck Surfaces

Commentary:

Traction can be a characteristic of the decking material itself. For example, extruded aluminum decking frequently used for gangway decks typically has patterns of small continuous raised ridges that provide good traction. Such decking can be enhanced by running the decking material through a knurling roller that imparts small v-grooves across the ridges at close intervals. This interrupts the continuous ridges, resulting in a multiple-row tooth-like surface that provides excellent traction. Such serrated metal decking provides good service, but if manufactured from relatively “soft” aluminum alloys, the aluminum serrations will probably wear smooth in high traffic areas within a few years. This can result in loss of traction and slick conditions when wet and when at steeper slopes.

Various deck coatings can provide excellent traction on both new and altered gangways. However, attention to detail during application of the coatings is critical. Consideration must be given to temperature, humidity, surface preparation, porosity of the decking, product selection and adherence to manufacturer's recommendations. Also, coated gangways must be touched up or re-coated periodically in order to maintain safe and suitable traction and appearance. Gangway coatings usually consist of binder base materials such as acrylic resin or latex that contain fine aggregate materials such as silica sand, Carborundum, ground walnut shells or other hard durable materials that provide a long-wearing non-slip surface. Keep in mind that as the binder material wears, the incorporated aggregate material will progressively come into view, sometimes resulting in gradual changes in surface texture and color.

Characteristics of a suitable deck coating should include flexibility, good bonding, and resistance to deterioration from UV and minerals in local water. Darker colors are probably more resistant to UV damage, but also absorb the most heat from sunlight during the spring, summer and fall boating season. The presence of salt, alkali and other mineral components may be detrimental to the integrity and service life of the coating, and ultimately to the gangway structure. Flexibility is critical to enable the coating to bend and flex in accordance with the dynamic nature of a gangway, and to properly respond to thermal expansion and contraction of the gangway during daily and seasonal temperature cycles.

On new construction, gangway coatings typically are applied in fabrication shops under controlled conditions. However, field application of gangway coatings should be performed either (1) on shore after temporary removal of a gangway, or (2) in place over water using approved procedures to repair and/or remove existing coatings and apply new materials. Containment methods must be employed to catch, contain and remove any coating materials, new or removed, that could enter the water as chips, dust, vapor, spray, drips or spills.

How aggressive a surface texture to provide on a gangway is a local judgment call that must be tempered by local conditions and consideration of the users. If a surface is too smooth, it will not provide adequate traction on steep slopes when wet. If too aggressive and rough, it may be suitable to boot-wearing persons engaged in commercial fishing, but be totally unsatisfactory for young children wearing shorts who are prone to falling down and scuffing their hands and knees. Also, some senior citizens who are only able to slightly lift their feet when walking will sometimes have problems with their shoes catching on surfaces that are too aggressive. Additionally, the rougher the surface, the faster the high points wear, and the more difficult it is to keep clean and serviceable.

The color of a gangway decking is important. Metal decking should be lightly blasted to remove the shine that can be overly bright on sunny days. Such light blasting removes oil and fabrication residue, and is excellent preparation for application of deck coatings. Dark colors are to be avoided as they become hot during summer days, and can actually burn bare feet. The absorbed heat from dark

surface colors also can have a negative impact on adhesives that bond coatings to the gangway decking material.

The use of truck bed sprayed-on coatings is a possible solution for gangway coatings that can be applied either in a shop or in the field. These durable polyurethane based coatings have become very popular for use in pickup trucks. They are available in a number of colors and when applied to a gangway, can provide traction for pedestrian traffic as well as protection against corrosion. If a more aggressive surface texture is required, mineral aggregates can be mixed into the polyurethane to provide various degrees of surface traction.

F2.8 Cleats on Gangway Decks

Commentary:

In cases where cleats are considered necessary on a gangway deck, the cleats should not extend across the full width of the gangway, but be confined to a strip down the center of the gangway. The length of such cleats should be determined on the basis of the axle lengths of the carts and dollies expected to be used on specific gangways. In general, a rule of thumb for cleat lengths on narrow gangways (not over 48 inches wide) is about 40% of the clear width of the gangway. On a gangway that has a clear width of 48 inches, the maximum length of the cleats would be about 19-20 inches. This will provide a “cleatless lane” down each side of the gangway deck for the unobstructed passage of equipment, carts and dollies that roll on wheels, but still provide cleats for specified needs.



Cleats @ 12" Centers Across Gangway Deck

F2.9.1 Maximum Gangway Slopes — On Coastal Waterways

F2.9.2 Maximum Gangway Slopes — On Inland Waterways

Commentary:

Gangways steeper than 2½:1 are difficult for many persons to use, including children, senior citizens and persons who are carrying supplies and equipment to and from their boats. Steep gangway slopes are particularly troublesome if a gangway remains at a steep slope for long periods. Such could be the case at an inland lake, reservoir or river where late summer, fall and winter water levels can remain seasonally low for several months, or even for years during prolonged droughts.

Maximum gangway slopes are influenced by water level fluctuations, size of marina basins, number of berths, shoreline topography, marina berthing layouts and gangway lengths. At some sites, constraints on shore and on the docks can dictate

rather short gangways that are steep at low water levels. The 2½:1 maximum slope guideline acts as an umpire in the best interests of both landside and dockside constraints, and the safe long-term usability of a gangway.

F2.13 Gangway Utility Connections

Commentary:

The utility connections at the top and bottom end of a gangway must flex with the changing gangway slope as water levels rise and fall, and must be highly reliable to provide public safety and insure against leaks, breaks and failures that would result in contamination of the water in a marina basin. The materials used for these critically important utility components must be highly resistant to corrosion, non-hardening from years of bending cycles, UV resistant and suitable for the utility service they provide.

A typical design for gangway utility lines includes loops at both the top and bottom of a gangway to provide the slack necessary to avoid developing tension in the lines that could result in damage and/or failure. The dead weight of the lines and any fluids they may be carrying, causes additional forces to be transferred to the actual connections. Therefore, the use of “line slings” or “locking nets” made of fine stainless steel cable material will relieve the connections from supporting the weight of the lines as it is transferred to the slings or nets and on to the pier, gangway or dock.

F2.14 ADA and ADA-ABA Reference Numbers

Commentary:

Reference numbers in the following sections refer to specific requirements in ADAAG which was edited and re-published by the Access Board in 2004 under the new title ADA-ABA, a document that combines the accessibility guidelines from the Americans With Disabilities Act (ADA) with the accessibility guidelines from the Architectural Barriers Act (ABA). At the time of publication of this 2005 Layout & Design GUIDELINES for Marina Berthing Facilities, the ADA-ABA is being reviewed by the federal Department of Justice, the enforcement agency for these federal accessibility guidelines. Until ADA-ABA is officially approved by DOJ, ADAAG is still in effect and must be complied with.

See Appendix B for a side-by-side comparison table of the complete text of both ADAAG 15.2 and ADA-ABA 1003 and 235. The cited sections in both documents address particular accessibility guidelines for recreational boating facilities.

F2.14.6 Alteration or Replacement of Gangways

Commentary:

An example of such a case would be the provision of additional marina berths of a different size or with different utility services. The addition of a completely new marina component such as a fuel dock or other new service would constitute a

APPENDIX A - COMMENTARY

SECTION G - LAND AREAS

LAND AREAS

G1.2 Minimum Number of Parking Spaces

Commentary:

The minimum parking requirement is to be utilized where self-parking is provided for marina patrons, including persons with disabilities. This level of parking is specifically for support of the users of the boat berths, and is not intended to address the parking needs of visitors, offices, restaurants, concessionaire operations, retail businesses, chandleries, fishing piers, boat launching ramps, park and picnic areas, government agencies and other entities and activities that require vehicle parking at a marina.

G1.2.2 Parking Spaces for Commercial Fishing Boats

Commentary:

Where mixtures of recreational and commercial fishing boat berths are provided in marinas, the minimum parking capacity requirement for commercial fishing boat berths is higher because of additional parking demand for crew members, support vehicles (supplies and equipment) and others typically involved in commercial fishing operations.

G1.2.3.3 Types of Accessible Parking Spaces

Commentary:

Designated barrier-free spaces are to be provided for each type of parking that is provided. It is not intended that this will increase the number of required accessible parking spaces. For example, at a marina with 365 parking spaces, the required minimum number of accessible parking spaces is eight (8), as per Table G -1. Where there is little demand for van and recreational vehicle parking, a reasonable parking plan would include six (6) accessible single parking spaces, one (1) van space, and one (1) recreational vehicle space, for a total of eight (8).

G1.3.1.1 Option for Reduced Width of Van Accessible Parking Space Access Aisles

Commentary:

The normal overall width of a van accessible space is 16 ft; 8 ft for the van parking space and 8 ft for the adjacent access aisle. This option will maintain the overall 16 ft width, but permits the parking space to be widened to 11 ft, and the access aisle to be reduced to 5 ft, the normal access aisle width for other accessible parking spaces. This option has two advantages:

1. It eliminates the problem of people mistaking an 8 ft wide access aisle for an 8 ft wide parking space, particularly in the rain at night when pavement markings, stripes, etc. are difficult to see. The fine for parking in an access aisle is the same as for parking in an accessible parking space without a legal handicap placard or license plate sticker.

2. The lift provided on vans is typically located on the passenger side of the van. Depending on the circumstances, the access aisle may be on either the right or left side of the parking space. An example situation is where two accessible parking spaces share a common access aisle between them. The access aisle will be on the right side of one space and on the left side of the other. If one or both of the parking spaces is designated “van accessible” and made 11 ft wide, the extra width provides “wiggle room” allowing a driver to park a little more to the left or right in order to enhance exiting or entering the parked vehicle and utilizing the access aisle.

Van accessible parking spaces are not reserved, and may be used by anyone with a proper placard or license plate sticker. The intent of the designation is to inform van drivers that the spaces are particularly suited for parking vans.

G1.4.3 Special Local Requirements for Parking Areas

Commentary:

For example, one major California city has a “shade requirement” that 25 years after completion of a new paved parking area, 50 percent of the parking area must be in shade at noon on July 1st. This requirement cannot be met without the provision of landscaped islands provided throughout the parking areas.

G2.2 Unisex Restroom Facilities

Commentary:

Unisex facilities are particularly helpful for families with small children. Also, adults who are injured, disabled, elderly or otherwise in need of assistance from a spouse or partner of the opposite sex, will greatly benefit from the provision of unisex toilet facilities. Such facilities help solve various cultural and social issues that would otherwise be problems for certain users and marina operators.

G2.4 Minimum Number of Restroom Toilet Fixtures

Commentary:

Common sense and practicality must prevail in determining how many restroom buildings are necessary at a given marina, the spacing distances between restroom buildings, how many toilet fixtures to provide in each restroom building, how many toilet stools in combinations with urinals to provide in men’s restrooms, the number of berths to be served by each restroom facility, and how to provide unisex restroom facilities in place of, or in combo with, conventional men / women toilet compartments.

.....
G2.5 Ultra-Low Flush Toilets (ULF)

Commentary:

Following the passage of the 1992 Energy Act, California is one of about 40 states that has developed regulations that require ULF toilets be used in all new buildings, as well as in remodels and expansions.

.....
G2.6 Sanitary Public Restrooms

Commentary:

The architectural design of public restrooms in marinas should take advantage of the array of new and innovative building materials that provide safe, sanitary, durable, attractive and cost effective service to the boating public. The architectural motif of such facilities should be appropriate for the site and compatible with existing structures and buildings. Material selections should address the wet environment typical in public restrooms which are often washed out with water hoses. Porous materials such as concrete floors should be avoided to guard against cultivating molds and bacteria that thrives in a wet environment. Ceramic tiles on the floors and walls are durable, easy to seal and keep clean, are vandal resistant to painting and marking, and are fairly easy to chip out and replace when damaged. Maintenance of tile floors may be a little more expensive than bare concrete floors, but they are more user friendly, have a better appearance, can brighten the interior of a restroom and are probably more sanitary.

.....
G3.2 Boat Launching Facilities

Commentary:

A boat launching facility located deep inside a marina fairway in which live-aboard boats are berthed is a potential social problem. People on the live-aboard boats may not be thrilled with the Saturday or Sunday 5:00 AM launching crowd during salmon season!

Also, boat wakes from boats leaving and returning to a boat ramp located deep within a marina causes additional wear on docks, piles, pile rollers, and disturbs boaters who are occupying their boats.

APPENDIX B

ADAAG 15.2 / ADA-ABA 1003 ACCESSIBLE BOATING FACILITIES

Background.

The Architectural Barriers Act (ABA) was passed by Congress in 1967, and subsequently ABA Guidelines were developed and published.

The Americans with Disabilities Act (ADA) was passed by Congress in 1990 and the following year the Americans with Disabilities Accessibility Guidelines (ADAAG) were approved and published by the Architectural and Transportation Barriers Compliance Board (ATBCB, commonly known as the Access Board). ADAAG provides guidelines for compliance with the ADA, including general information, instructions, definitions, accessible elements and spaces restaurants and cafeterias, medical facilities, places of business, civic facilities, libraries, transient lodging, transportation facilities, judicial and legislative facilities, detention and correctional facilities, residential housing, public rights-of-way, and **recreational facilities**. ADAAG 15 is the section in which recreation facilities are addressed, and ADAAG 15.2 addresses Recreational Boating Facilities.

When ADAAG was published in 1991, ADAAG 15 was held in reserve pending research, investigation and development of appropriate criteria upon which to base accessibility guidelines for recreational facilities. In 2002, ADAAG 15 was finally published by the Access Board. However, in July 2004, the Access Board published a new accessibility guideline called the Americans with Disabilities Act - Architectural Barriers Act (ADA-ABA), a merged document containing guidelines from both the 1967 ABA guidelines and the 1991 ADA guidelines.

The ADA-ABA guidelines are now being reviewed by the federal Department of Justice (DOJ), and upon approval will become federal rules that will be enforced by DOJ. In the meantime, ADAAG is still applicable and should be complied with. How soon DOJ will approve the new ADA-ABA is not known at this time.

Comparison of the ADAAG and the ADA-ABA.

In merging the two guideline documents, they were edited and completely re-formatted. The table on the next page of this appendix shows ADAAG 15.2 in the left column, and ADA-ABA Chapter 10 in the right column, complete with all of the cross references unique to the two guidelines. Where particular guidelines have been carried over into ADA-ABA, the text is the same or similar in opposite columns. Where changes or deletions occur, blank spaces will be seen in one or the other columns.

ADAAG ADA-ABA Comparison Chart

(Published by Access Board on September 3, 2002)

(Published by Access Board on July 23, 2004)
(Published in Federal Register by DOJ September 30, 2004)

Americans with Disabilities Accessibility Guidelines

ADAAG Section 15.2 Recreational Boating Facilities

15.2 Boating Facilities.

15.2.1 General. Newly designed or newly constructed and altered boating facilities shall comply with 15.2.

15.2.2 Accessible Route. Accessible routes, including gangways that are part of accessible routes, shall comply with 4.3.

Americans with Disabilities Act—Architectural Barriers Act **ADA-ABA Chapter 10, Section 1003**

Recreational Boating Facilities

1003 Recreational Boating Facilities

1003.1 General. Recreational boating facilities shall comply with 1003.

1003.2 Accessible Routes. Accessible routes serving recreational boating facilities, including gangways and floating piers, shall comply with Chapter 4 except as modified by the exceptions in 1003.2.

1003.2.1 Boat Slips. Accessible routes serving boat slips shall be permitted to use the exceptions in 1003.2.1.

EXCEPTION 1. Where an existing gangway or series of gangways is replaced or altered, an increase in the length of the gangway is not required to comply with 15.2.2, unless required by 4.1.6(2).

EXCEPTION 2. The maximum rise specified in 4.8.2 shall not apply to gangways.

EXCEPTION 3. Where the total length of the gangway or series of gangways serving as part of a required accessible route is at least 80 feet (24 m), the maximum slope specified in

EXCEPTION 1. Where an existing gangway or series of gangways is replaced or altered, an increase in the length of the gangway shall not be required to comply with 1003.2 unless required by 202.4.

EXCEPTION 2. Gangways shall not be required to comply with the maximum rise specified in 405.6.

EXCEPTION 3. Where the total length of a gangway or series of gangways serving as part of a required accessible route is 80 feet (24 m) minimum, gangways shall not be

4.8.2 shall not apply to the gangways.

EXCEPTION 4. In facilities containing fewer than 25 boat slips and where the total length of the gangway or series of gangways serving as part of a required accessible route is at least 30 feet (9140 mm), the maximum slope specified in 4.8.2 shall not apply to the gangways.

EXCEPTION 5. Where gangways connect to transition plates, landings specified by 4.8.4 shall not be required.

EXCEPTION 6. Where gangways and transition plates connect and are required to have handrails, handrail extensions specified by 4.8.5 shall not be required. Where handrail extensions are provided on gangways or transition plates, such extensions are not required to be parallel with the ground or floor surface.

EXCEPTION 7. The cross slope of gangways, transition plates, and floating piers that are part of an accessible route shall be 1:50 maximum measured in the static position.

EXCEPTION 8. Limited-use/limited-application elevators or platform lifts complying with 4.11 shall be permitted in lieu of gangways complying with 4.3.

required to comply with 405.2.

EXCEPTION 4. Where facilities contain fewer than 25 boat slips and the total length of the gangway or series of gangways serving as part of a required accessible route is 30 feet (9145 mm) minimum, gangways shall not be required to comply with 405.2.

EXCEPTION 5. Where gangways connect to transition plates, landings specified by 405.7 shall not be required.

EXCEPTION 6. Where gangways and transition plates connect and are required to have handrails, handrail extensions shall not be required. Where handrail extensions are provided on gangways or transition plates, the handrail extensions shall not be required to be parallel with the ground or floor surface.

EXCEPTION 7. The cross slope specified in 403.3 and 405.3 for gangways, transition plates, and floating piers that are part of accessible routes shall be measured in the static position.

EXCEPTION 8. Changes in level complying with 303.3 and 303.4 shall be permitted on the surfaces of gangways and boat launch ramps.

15.2.3 Boat Slips: Minimum Number. Where boat slips are provided, boat slips complying with 15.2.5 shall be provided in accordance with Table 15.2.3. Where the number of boat slips is not identified, each 40 feet (12 m) of boat slip edge provided along the perimeter of the pier shall be counted as one boat slip for the purpose of this section.

Table 15.2.3

Total Boat Slips in Facility	Minimum Number of Required Accessible Boat Slips
1 to 25	1
26 to 50	2
51 to 100	3
101 to 150	4
151 to 300	5
301 to 400	6
401 to 500	7
501 to 600	8
601 to 700	9
701 to 800	10
810 to 900	11
901 to 1000	12
1001 and over	12, plus 1 for each 100 or fraction thereof over 1000

235.2 Boat Slips. Boat slips complying with 1003.3.1 shall be provided in accordance with Table 235.2. Where the number of boat slips is not identified, each 40 feet of boat slip edge provided along the perimeter of the pier shall be counted as one boat slip for the purpose of this section.

235.2 Boat Slips

Total Number of Boat Slips Provided in Facility	Minimum Number of Required Accessible Boat Slips
1 to 25	1
26 to 50	2
51 to 100	3
101 to 150	4
151 to 300	5
301 to 400	6
401 to 500	7
501 to 600	8
601 to 700	9
701 to 800	10
810 to 900	11
901 to 1000	12
1001 and over	12, plus 1 for each 100 or fraction thereof over 1000

15.2.3.1 Dispersion. Accessible boat slips shall be dispersed throughout the various types of slips provided. This provision does not require an increase in the minimum number of boat slips required to be accessible.

15.2.4 Boarding Piers at Boat Launch Ramps. Where boarding piers are provided at boat launch ramps, at least 5 percent, but not less than one of the boarding piers shall comply with 15.2.4 and shall be served by an accessible route complying with 4.3.

EXCEPTION 1. Accessible routes serving floating boarding piers shall be permitted to use Exceptions 1, 2, 5, 6, 7 and 8 in 15.2.2.

EXCEPTION 2. Where the total length of the gangway or series of gangways serving as part of a required accessible route is at least 30 feet (9140 mm), the maximum slope specified by 4.8.2 shall not apply to the gangways.

EXCEPTION 3. Where the accessible route serving a floating boarding pier or skid pier is located within a boat launch ramp, the portion of the accessible route located within the boat launch ramp shall not be required to comply with 4.8.

15.2.4.1 Boarding Pier Clearances. The entire length of the piers shall comply with 15.2.5.

235.2.1 Dispersion. Boat slips complying with 1003.3.1 shall be dispersed throughout the various types of boat slips provided. Where the minimum number of boat slips required to comply with 1003.3.1 has been met, no further dispersion shall be required.

235.3 Boarding Piers at Boat Launch Ramps. Where boarding piers are provided at boat launch ramps, at least 5 percent, but no fewer than one, of the boarding piers shall comply with 1003.3.2.

1003.2.2 Boarding Piers at Boat Launch Ramps. Accessible routes serving boarding piers at boat launch ramps shall be permitted to use the exceptions in 1003.2.2.

EXCEPTION 1. Accessible routes serving floating boarding piers shall be permitted to use Exceptions 1, 2, 5, 6, 7 and 8 in 1003.2.1.

EXCEPTION 2. Where the total length of the gangway or series of gangways serving as part of a required accessible route is 30 feet (9145 mm) minimum, gangways shall not be required to comply with 405.2.

EXCEPTION 3. Where the accessible route serving a floating boarding pier or skid pier is located within a boat launch ramp, the portion of the accessible route located within the boat launch ramp shall not be required to comply with 405.

1003.3 Clearances. Clearances at boat slips and on boarding piers at boat launch ramps shall comply with 1003.3

15.2.5 Accessible Boat Slips. Accessible boat slips shall comply with 15.2.5.

15.2.5.1 Clearances. Accessible boat slips shall be served by clear pier space 60 inches (1525 mm) wide minimum and at least as long as the accessible boat slips. Every 10 feet (3050 mm) maximum of linear pier edge serving the accessible boat slips shall contain at least one continuous clear opening 60 inches (1525 mm) minimum in width.

EXCEPTION 1. The width of the clear pier space shall be permitted to be 36 inches (915 mm) minimum for a length of 24 inches (610 mm) maximum, provided that multiple 36 inch (915 mm) wide segments are separated by segments that are 60 inches (1525 mm) minimum clear in length.

EXCEPTION 2. Edge protection 4 inches (100 mm) high maximum and 2 inches (51 mm) deep maximum shall be permitted at the continuous clear openings.

EXCEPTION 3. In alterations to existing facilities, clear pier space shall be permitted to be located perpendicular to the boat slip and shall extend the width of the boat slip, where the facility has at least one boat slip complying with 15.2.5, and further compliance with 15.2.5 would result in a reduction in the number of boat slips available or result in a reduction of the widths of existing slips.

1003.3.1 Boat Slip Clearance. Boat slips shall provide clear pier space 60 inches (1525 mm) wide minimum and at least as long as the boat slips. Each 10 feet (3050 mm) maximum of linear pier edge serving boat slips shall contain at least one continuous clear opening 60 inches (1525 mm) wide minimum.

EXCEPTION 1. Clear pier space shall be permitted to be 36 inches (915 mm) wide minimum for a length of 24 inches (610 mm) maximum, provided that multiple 36 inch (915 mm) wide segments are separated by segments that are 60 inches (1525 mm) wide minimum and 60 inches (1525 mm) long minimum.

EXCEPTION 2. Edge protection shall be permitted at the continuous clear openings, provided that it is 4 inches (100 mm) high maximum and 2 inches (51 mm) wide maximum.

EXCEPTION 3. In existing piers clear pier space shall be permitted to be located perpendicular to the boat slip and shall extend the width of the boat slip, where the facility has at least one boat slip complying with 1003.3, and further compliance with 1003.3 would result in a reduction in the number of boat slips available or result in a reduction in the widths of existing slips.

1003.3.2 Boarding Pier Clearances. Boarding piers at boat launch ramps shall provide clear pier space 60 inches (1525 mm) wide minimum and shall extend the full length of the boarding pier. Every 10 feet (3050 mm) maximum of linear pier edge shall contain at least one continuous clear opening 60

inches (1525 mm) wide minimum.

EXCEPTION 1. The clear pier space shall be permitted to be 36 inches (915 mm) wide minimum for a length of 24 inches (610 mm) maximum provided that multiple 36 inch (915 mm) wide segments are separated by segments that are 60 inches (1525 mm) wide minimum and 60 inches (1525 mm) long minimum.

EXCEPTION 2. Edge protection shall be permitted at the continuous clear openings provided that it is 4 inches (100 mm) high maximum and 2 inches (51 mm) wide maximum.

15.2.5.2 Cleats and Other Boat Securement Devices. Cleats and other boat securement devices shall not be required to comply with 4.27.3.

❖ ❖ ❖ End of ADAAG 15.2 ❖ ❖ ❖

❖ ❖ ❖ End of ADA-ABA 1003 ❖ ❖ ❖

